

# PARTS CATALOGUE

<b>XJR1200'96</b>	<b>(4PU3)</b>	<b>EUROPE</b>
<b>XJR1200'96</b>	<b>(4PU4)</b>	<b>SPAIN</b>
<b>XJR1200'96</b>	<b>(4RB2)</b>	<b>SWITZERLAND, AUSTRIA</b>
<b>XJR1200H</b>	<b>(4UW1)</b>	<b>OCEANIA</b>

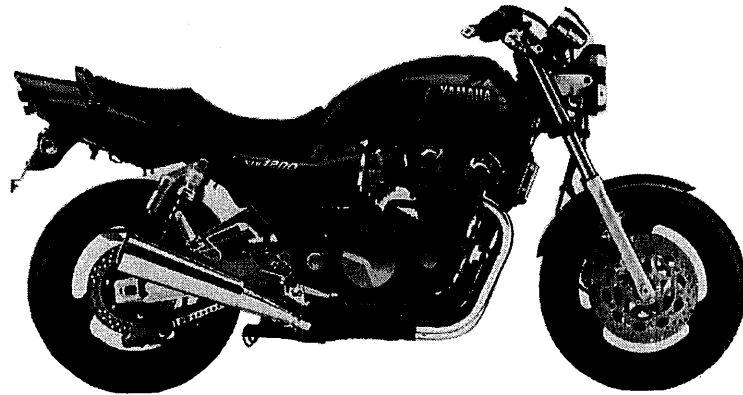
164PU-300E1

**YAMAHA**  
**GENUINE**  
Parts & Accessories

NEWS No.	DATE	COMMENT
PE0-MC-110020	Mar.,28,2011	FIG.27 SEAT ILLUSTRATION CORRECTION

2011-3-29





A3



## FOREWORD

This Parts Catalogue is related to the parts for the model(s) in the below frame. When you are ordering replacement parts, please refer to this Parts Catalogue and quote both part numbers and part names correctly.

XJR1200'96(4PU3,4PU4,4RB2), XJR1200H(4UW1)

- Modifications or additions which have been made after issue of the Parts Catalogue will be announced in the Yamaha Parts News.  
It is advisable that you make necessary corrections to the Parts Catalogue according to the Yamaha Parts News.

2. Abbreviations

The following abbreviations are used in this Parts Catalogue.

- "UR" Use specified parts number.
- "UN" Use as many as needed.
- "AP" Alternate Parts
- "LM" Local Made (Parts need to be ordered locally)
- "F#" Frame No. (Applicable machine No.)

- Parts, which are to be supplied in an assembly, are listed with a dot (.) in front of the part name as shown below.

EXAMPLE

- CARBURETOR ASSY
- . JET, PILOT
- . NOZZLE, MAIN

- Number of component for assembly

The numeral appearing to the right of each component part indicates the quantity of parts for each assembly unit.

EXAMPLE

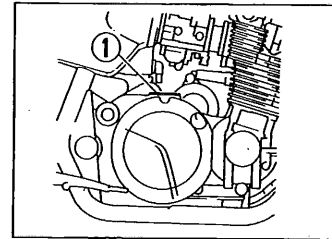
PART NO.	DESCRIPTION	Q'TY	REMARKS
2F5-83310-60	FRONT FLASHER LIGHT ASSY	2	
115-83311-60	. BULB (6V-18W)	1	

- Applicable colors of graphics are represented in the "REMARKS" as shown below.

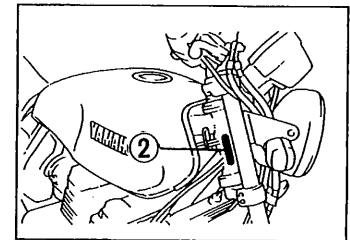
PART NO.	DESCRIPTION	Q'TY	REMARKS
2N4-24110-00-X5	FUEL TANK COMP.	1	MAXIM RED
3J1-24240-10	. GRAPHIC, FUEL TANK	1	for MXR

- Applicable Serial No.

① Engine Serial No.



② Frame Serial No.



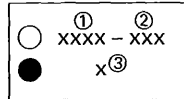
- Note that the illustrations are for reference in finding parts numbers, not to be used for assembling. When assembling, please use the applicable service manual.

- The asterisk (\*) before a reference number indicates modification items after the first edition.

## MODEL LABEL

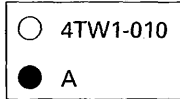
(1) A label called "Model Label" is affixed in the location as indicated in (3) below. When using this parts catalogue, please be sure to cross-refer the "model code - production code No." in the catalogue to the "model code - production code No." indicated on the Model Label affixed onto the product concerned.

(2) "Model Label" Indication

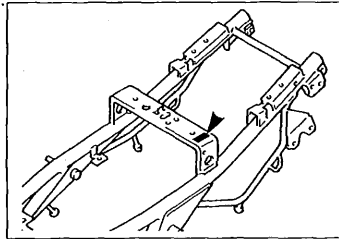


- ① Model Type Code
- ② Production Code No.
- ③ Colouring Type

ex



(3) Model Label Affixing Location



(4) Model Code - Production Code Number of Model Listed in This Parts Catalog

Model code	Production code No.	Country (destination)	Model code	Production code No.	Country (destination)
4PU3	020	BELGIUM			
	030	DENMARK			
	050	ENGLAND			
	060	GREECE			
	070	ITALY			
	080	HOLLAND			
	090	NORWAY			
	100	PORTUGAL			
	110	SWEDEN			
	4PU4	010	SPAIN		
4RB2	010	SWITZERLAND			
	020	AUSTRIA			
4UW1	010	AUSTRALIA			

(5) Colouring Information

Colouring type code	Colour code	Colour Name	Abbreviation
A	004B	BLACK 2	BL2
B	0376	DEEP RED COCKTAIL 2	DRC 2

# CONTENTS

## ENGINE

Cylinder Head .....	B2
Cylinder .....	B3
Crankshaft · Piston .....	B4
Valve .....	B5 ~ B6
Camshaft · Chain .....	B7
Oil Pump .....	B8
Oil Cooler .....	B9
Oil Cleaner .....	B10
Intake .....	B11
Carburetor .....	B12 ~ B13
Exhaust .....	B14
Crankcase .....	B15 ~ C2
Crankcase Cover 1 .....	C3 ~ C4
Starter .....	C5
Clutch .....	C6 ~ C7
Transmission .....	C8 ~ C9
Shift Cam · Fork .....	C10
Shift Shaft .....	C11

## CHASSIS

Frame .....	C12
Fender .....	C13 ~ C15
Side Cover .....	D2
Rear Arm .....	D3
Rear Suspension .....	D4
Steering .....	D5

Front Fork .....	D6 ~ D7
Fuel Tank .....	D8 ~ D9
Seat .....	D10
Front Wheel .....	D11
Front Brake Caliper .....	D12
Rear Wheel .....	D13 ~ D14
Rear Brake Caliper .....	D15
Steering Handle · Cable .....	E2
Front Master Cylinder .....	E3
Front Master Cylinder 2 .....	E4
Stand · Footrest .....	E5 ~ E6
Rear Master Cylinder .....	E7 ~ E8
Generator .....	E9
Pick Up Coil · Governor .....	E10
Starting Motor .....	E11
Flasher Light .....	E12
Meter .....	E13 ~ E14
Headlight .....	E15 ~ F2
Taillight .....	F3
Electrical 1 .....	F4
Electrical 2 .....	F5

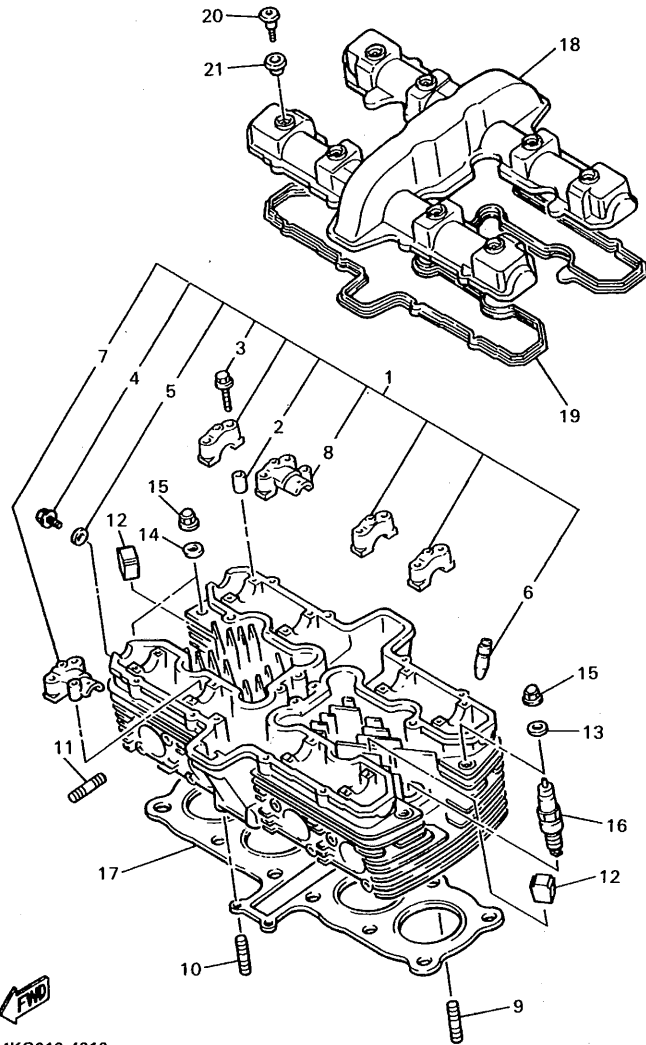
## INDEX

NUMERICAL INDEX .....	L1 ~ L4
-----------------------	---------





FIG. 1 CYLINDER HEAD

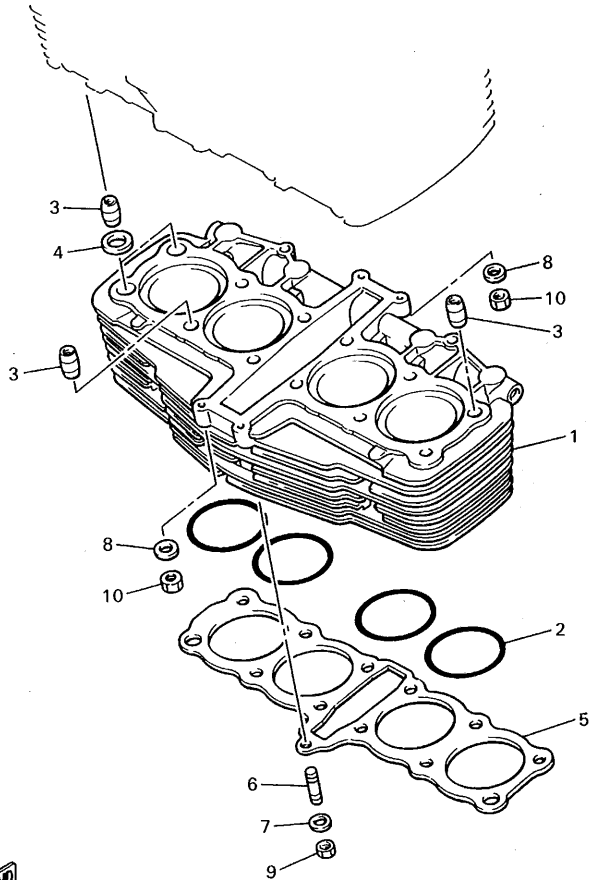


4KG010-4010

REF. NO.	PART NO.	DESCRIPTION	Q'TY	REMARKS
1	4KG-11101-00	CYLINDER HEAD ASSY	1	
2	99510-08016	•PIN, DOWEL	16	
3	90105-06305	•BOLT, WASHER BASED	18	
4	90153-06029	•SCREW, HEXAGON	1	
5	90430-06014	•GASKET	1	
6	36Y-11133-10	•GUIDE, INTAKE VALVE	16	
7	36Y-12193-10	•CAP, CAMSHAFT 3	1	
8	36Y-12178-10	•CAP, CAMSHAFT 4	1	
9	95617-06625	BOLT, STUD	2	
10	95617-06635	BOLT, STUD	2	
11	95617-08625	BOLT, STUD	8	
12	434-11161-00	ABSORBER 1	16	
13	90201-102G9	WASHER, PLATE	10	
14	90201-10128	WASHER, PLATE	2	
15	90176-10078	NUT, CROWN	12	
16	94701-00241	PLUG, SPARK (NGK DPR8EA-9)	4	
17	1TX-11181-00	GASKET, CYLINDER HEAD 1	1	
18	4KG-11191-01	COVER, CYLINDER HEAD 1	1	
19	36Y-11193-00	GASKET, HEAD COVER 1	1	
20	90109-066F0	BOLT	8	
21	4KG-1111G-00	RUBBER, MOUNT 1	8	

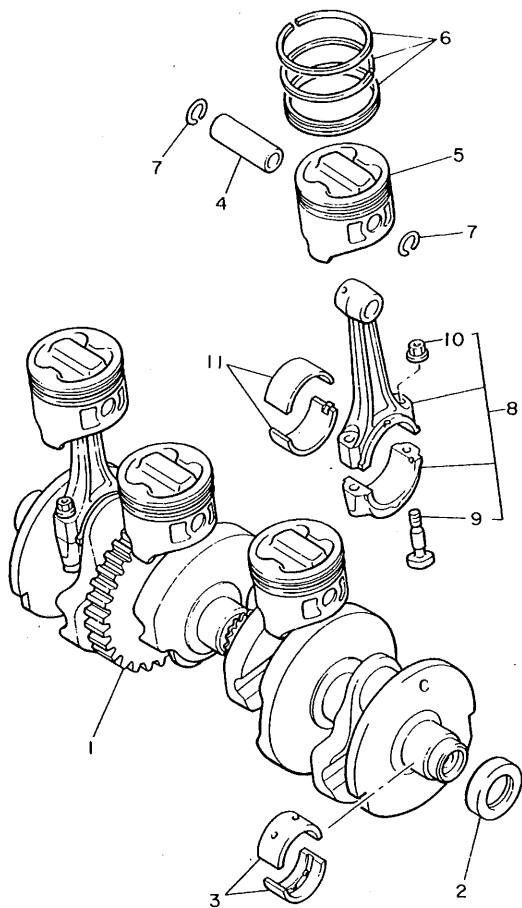
FIG. 2 CYLINDER

REF. NO.	PART NO.	DESCRIPTION	Q'TY	REMARKS
1	1TX-11310-01	CYLINDER	1	
2	93210-81731	O-RING	4	
3	99530-14016	PIN, DOWEL	4	
4	90430-14131	GASKET	2	
5	4CR-11351-00	GASKET, CYLINDER	1	
6	95627-08330	BOLT, STUD	1	
7	90201-084G3	WASHER, PLATE	1	
8	92907-06600	WASHER	4	
9	95317-08600	NUT	1	
10	95317-06600	NUT	4	



4KG010-4020

FIG. 3 CRANKSHAFT • PISTON

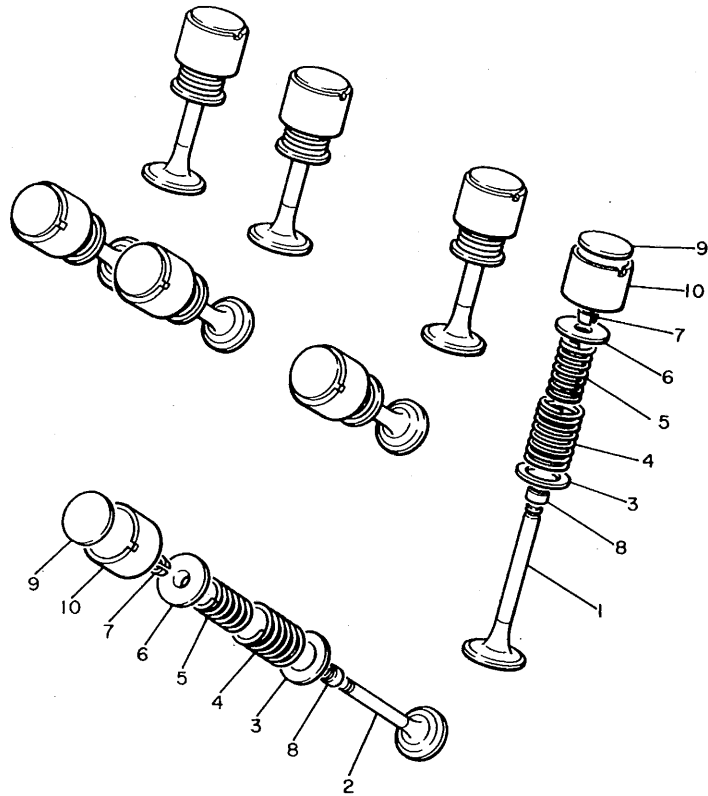


REF. NO.	PART NO.	DESCRIPTION	Q'TY	REMARKS
1	36Y-11411-01	CRANKSHAFT	1	
2	36Y-15389-09	OIL SEAL	1	
3	2H7-11416-01	PLANE BEARING, CRANKSHAFT 1	10	UR BLUE
	2H7-11416-11	PLANE BEARING, CRANKSHAFT 1	10	UR BLACK
	2H7-11416-21	PLANE BEARING, CRANKSHAFT 1	10	UR BROWN
	2H7-11416-31	PLANE BEARING, CRANKSHAFT 1	10	UR GREEN
	2H7-11416-41	PLANE BEARING, CRANKSHAFT 1	10	UR YELLOW
4	30X-11633-03	PIN, PISTON	4	
5	4PU-11631-00-A0	PISTON (STD)	4	
	4PU-11636-00	PISTON (0.50MM O/S)	4	AP
6	4PU-11603-00	PISTON RING SET (STD)	4	
	4PU-11605-00	PISTON RING SET (0.50MM O/S)	4	AP
7	93450-19052	CIRCLIP	8	
8	36Y-11650-01	CONNECTING ROD ASSY	4	
9	36Y-11654-00	•BOLT, CONNECTING ROD	2	
10	90179-08327	•NUT	2	
11	36Y-11656-00	PLANE BEARING, CONNECTING ROD	8	UR PINK
	36Y-11656-10	PLANE BEARING, CONNECTING ROD	8	UR BLUE
	36Y-11656-20	PLANE BEARING, CONNECTING ROD	8	UR BLACK
	36Y-11656-30	PLANE BEARING, CONNECTING ROD	8	UR BROWN



36Y310-4030

FIG. 4 VALVE



REF. NO.	PART NO.	DESCRIPTION	Q'TY	REMARKS
1	36Y-12111-00	VALVE, INTAKE	8	
2	36Y-12121-00	VALVE, EXHAUST	8	
3	26H-12116-00	SEAT, VALVE SPRING	16	
4	36Y-12114-00	SPRING, VALVE OUTER	16	
5	36Y-12113-00	SPRING, VALVE INNER	16	
6	30X-12117-00	RETAINER, VALVE SPRING	16	
7	30X-12118-00	COTTER, VALVE	32	
8	51Y-12119-00	SEAL, VALVE STEM	16	
9	26H-12168-00	PAD, ADJUSTING (2.00)	16	UR
	26H-12168-20	PAD, ADJUSTING (2.05)	16	UR
	26H-12168-40	PAD, ADJUSTING (2.10)	16	UR
	26H-12168-60	PAD, ADJUSTING (2.15)	16	UR
	26H-12168-80	PAD, ADJUSTING (2.20)	16	UR
	26H-12168-A0	PAD, ADJUSTING (2.25)	16	UR
	26H-12168-F0	PAD, ADJUSTING (2.30)	16	UR
	26H-12168-H0	PAD, ADJUSTING (2.35)	16	UR
	26H-12168-K0	PAD, ADJUSTING (2.40)	16	UR
	26H-12168-M0	PAD, ADJUSTING (2.45)	16	UR
	26H-12168-R0	PAD, ADJUSTING (2.50)	16	UR
	26H-12168-U0	PAD, ADJUSTING (2.55)	16	UR
	26H-12168-W0	PAD, ADJUSTING (2.60)	16	UR
	26H-12168-Y0	PAD, ADJUSTING (2.65)	16	UR
	26H-12169-10	PAD, ADJUSTING (2.70)	16	UR
	26H-12169-30	PAD, ADJUSTING (2.75)	16	UR
	26H-12169-50	PAD, ADJUSTING (2.80)	16	UR
	26H-12169-70	PAD, ADJUSTING (2.85)	16	UR
	26H-12169-90	PAD, ADJUSTING (2.90)	16	UR
	26H-12169-E0	PAD, ADJUSTING (2.95)	16	UR

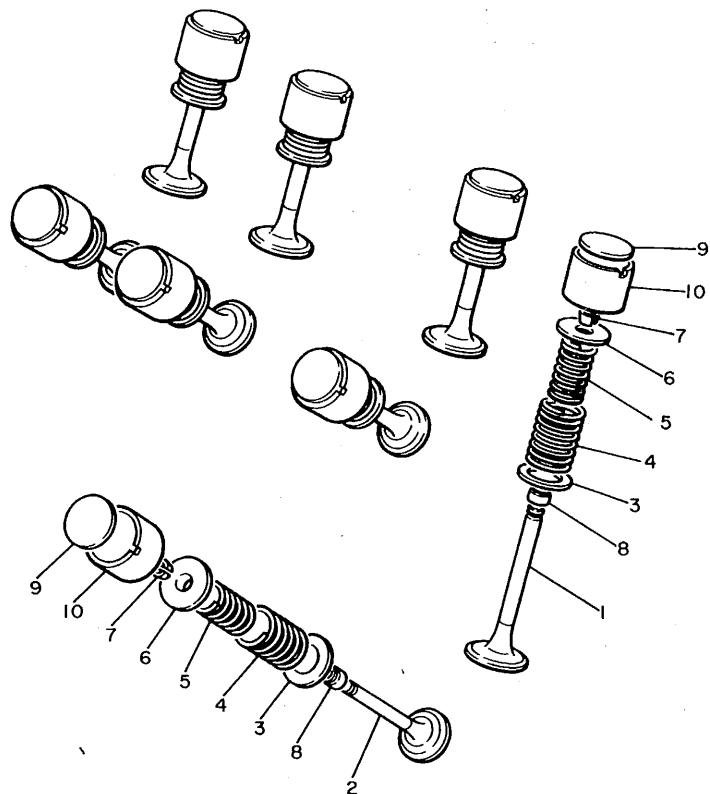


4H7110-0050

**B5**

FIG. 4 VALVE

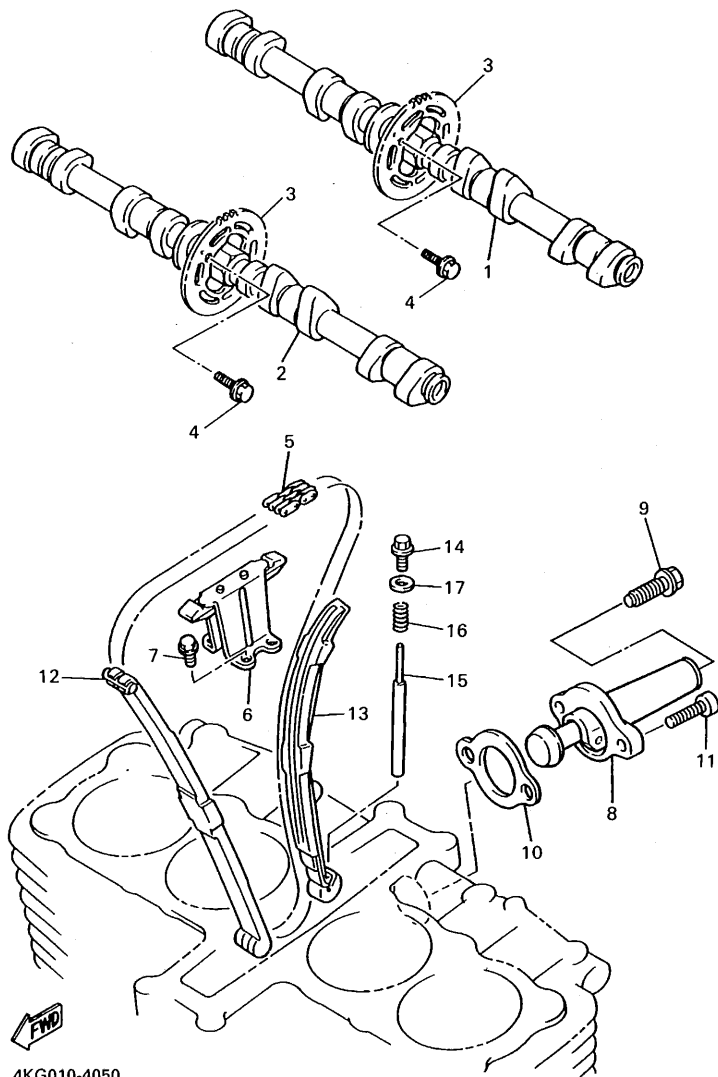
REF. NO.	PART NO.	DESCRIPTION	Q'TY	REMARKS
9	26H-12169-G0	PAD, ADJUSTING (3.00)	16	UR
	26H-12169-J0	PAD, ADJUSTING (3.05)	16	UR
	26H-12169-L0	PAD, ADJUSTING (3.10)	16	UR
	26H-12169-N0	PAD, ADJUSTING (3.15)	16	UR
	26H-12169-T0	PAD, ADJUSTING (3.20)	16	UR
	10	26H-12153-00-J0	LIFTER, VALVE(O/S)	16
26H-12153-00-Y0		LIFTER, VALVE	16	UR



4H7110-0050

**B6**

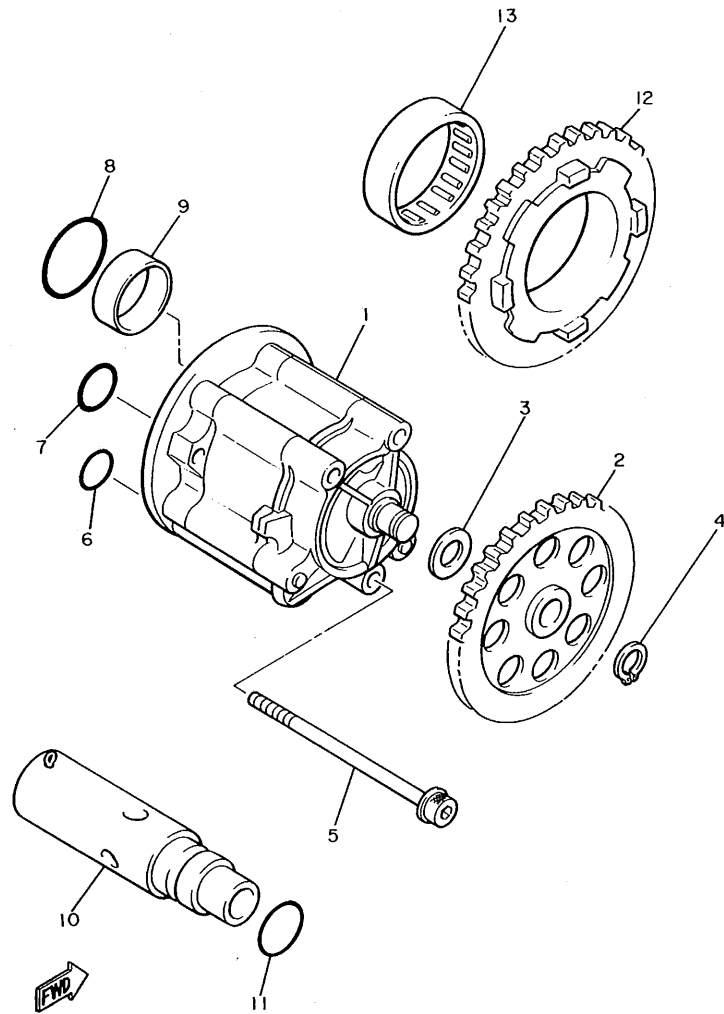
FIG. 5 CAMSHAFT • CHAIN



4KG010-4050

REF. NO.	PART NO.	DESCRIPTION	Q'TY	REMARKS
1	47M-12171-00	CAMSHAFT 1	1	
2	47M-12181-00	CAMSHAFT 2	1	
3	36Y-12176-00	SPROCKET, CAM CHAIN	2	
4	90105-07342	BOLT, WASHER BASED	4	
5	94591-05156	CHAIN	1	
6	36Y-12241-01	GUIDE, STOPPER 2	1	
7	90105-06424	BOLT, WASHER BASED	4	
8	4KG-12210-00	TENSIONER ASSY, CAM CHAIN	1	
9	4KG-12222-00	PLUG	1	
10	4BE-12213-00	GASKET, TENSIONER CASE	1	
11	91317-06025	BOLT	2	
12	36Y-12251-00	DAMPER, CHAIN 1	1	
13	36Y-12252-03	DAMPER, CHAIN 2	1	
14	90340-10108	PLUG, STRAIGHT SCREW	1	
15	90249-04184	PIN	1	
16	90501-153A2	SPRING, COMPRESSION	1	
17	90201-10118	WASHER, PLATE	1	

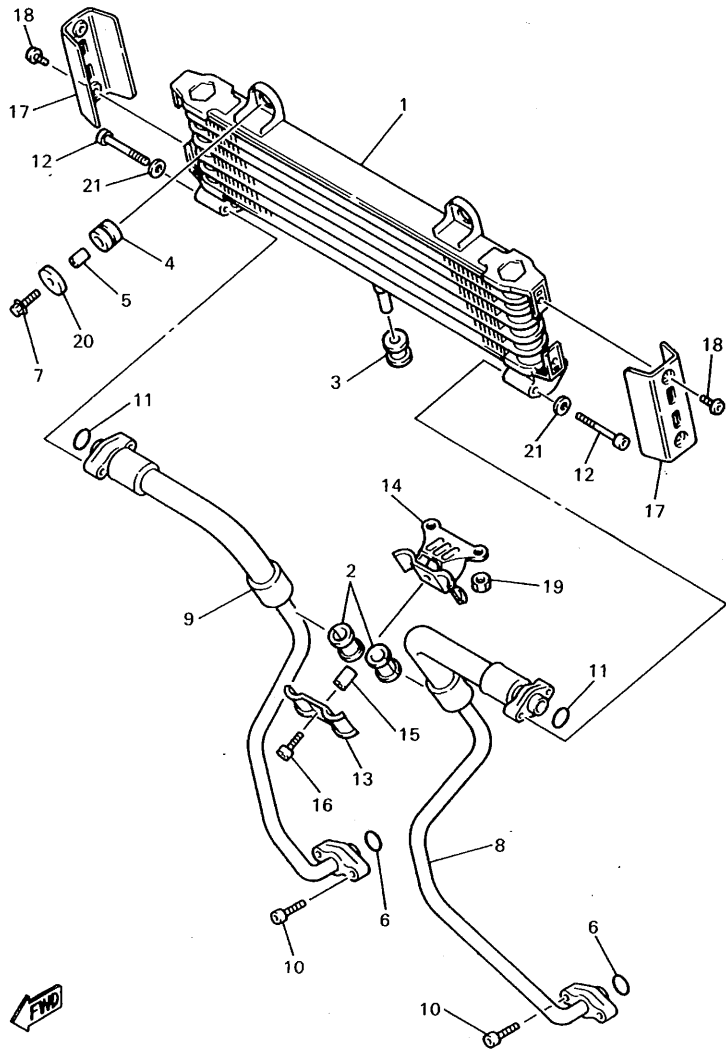
FIG. 6 OIL PUMP



36Y310-4060

REF. NO.	PART NO.	DESCRIPTION	Q'TY	REMARKS
1	3CV-13300-00	OIL PUMP ASSY	1	
2	36Y-13325-00	GEAR, PUMP DRIVEN (32T)	1	
3	90201-106H7	WASHER, PLATE	1	
4	93440-09139	CIRCLIP	1	
5	95817-06080	BOLT, FLANGE	3	
6	93210-13657	O-RING	1	
7	93210-15566	O-RING	1	
8	93210-26658	O-RING	1	
9	93626-08210	PIN, DOWEL	1	
10	36Y-13490-00	RELIEF VALVE ASSY	1	
11	93210-15566	O-RING	1	
12	36Y-13324-00	GEAR, PUMP DRIVE (36T)	1	
13	93315-23607	BEARING, CYLINDRICAL	1	

FIG. 7 OIL COOLER

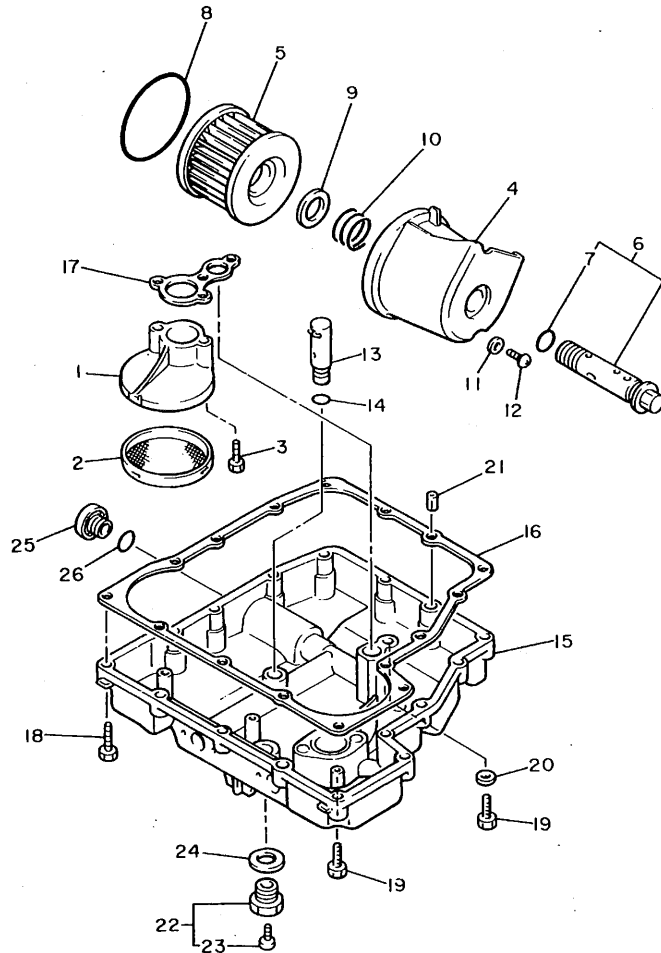


4KG010-4070

REF. NO.	PART NO.	DESCRIPTION	Q'TY	REMARKS
1	4KG-13470-00	OIL COOLER ASSY	1	
2	4KG-13159-00	DAMPER	2	
3	90480-16284	GROMMET	1	
4	90480-12475	GROMMET	2	
5	90387-060A7	COLLAR	2	
6	93210-13657	O-RING	2	
7	95817-06020	BOLT, FLANGE	2	
8	4KG-13464-00	HOSE, OIL 1	1	
9	4KG-13465-00	HOSE, OIL 2	1	
10	91317-06020	BOLT	4	
11	93210-16629	O-RING	2	
12	91317-06040	BOLT	4	
13	4KG-13151-00	STAY	1	
14	4KG-13152-00	STAY 2	1	
15	90387-060A7	COLLAR	1	
16	91317-06020	BOLT	1	
17	4HM-13463-00	COVER, OIL COOLER	2	
18	92014-06012	BOLT, BUTTON HEAD	4	
19	95317-06600	NUT	2	
20	90209-06174	WASHER	2	
21	92907-06200	WASHER	4	



FIG. 8 OIL CLEANER

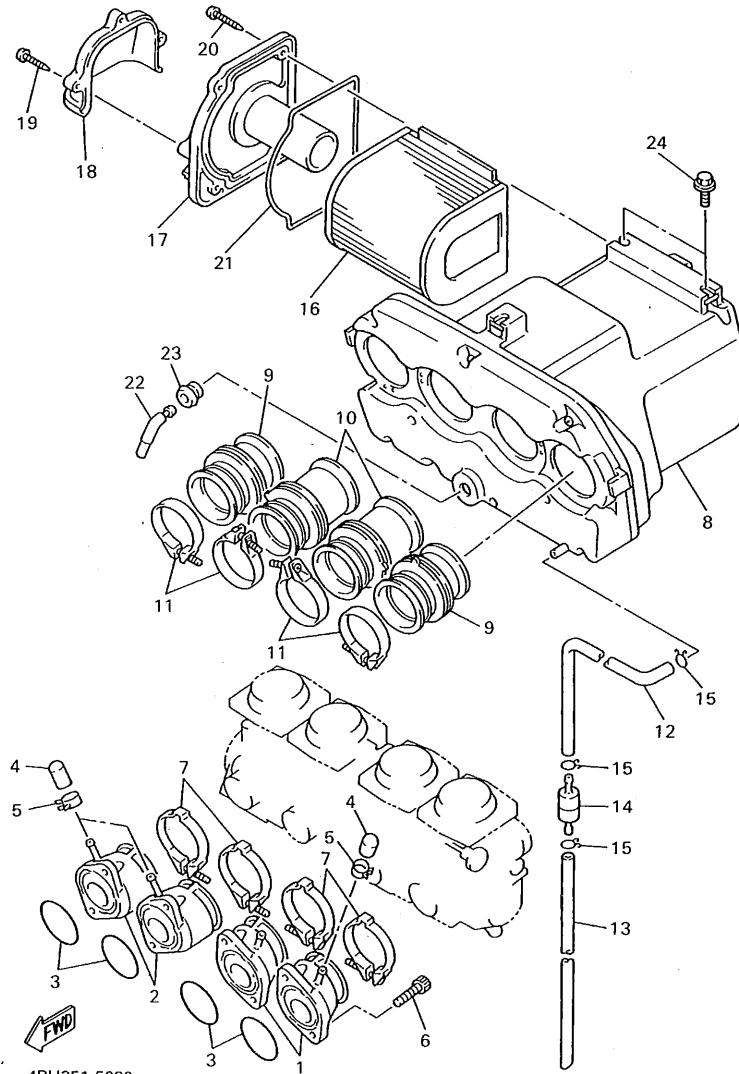


REF. NO.	PART NO.	DESCRIPTION	Q'TY	REMARKS
1	36Y-13412-00	HOUSING, STRAINER	1	
2	4H7-13411-02	STRAINER, OIL	1	
3	91317-06020	BOLT	2	
4	4KG-13447-00	COVER, OIL ELEMENT	1	
5	36Y-13441-00	ELEMENT, OIL CLEANER	1	
6	36Y-13340-00	BY-PASS VALVE ASSY	1	
7	93210-16629	O-RING	1	
8	93210-87723	O-RING	1	
9	90201-21608	WASHER, PLATE	1	
10	90501-20422	SPRING, COMPRESSION	1	
11	90430-05126	GASKET	1	
12	90149-05110	SCREW	1	
13	25G-13490-00	RELIEF VALVE ASSY	1	
14	93210-10096	O-RING	1	
15	36Y-13417-02	COVER, STRAINER	1	
16	4CR-13414-00	GASKET, STRAINER COVER	1	
17	4CR-13415-00	SEAL, OIL STRAINER	1	
18	91317-06025	BOLT	14	
19	90110-06237	BOLT, HEXAGON SOCKET HEAD	3	
20	90430-06014	GASKET	1	
21	99510-08016	PIN, DOWEL	2	
22	3VD-13455-00	PLUG	1	
23	98907-06008	SCREW, BIND	1	
24	214-11198-01	GASKET	1	
25	36Y-15189-00	PLUG	1	
26	93210-16629	O-RING	1	

 36Y310-4080

**B10**

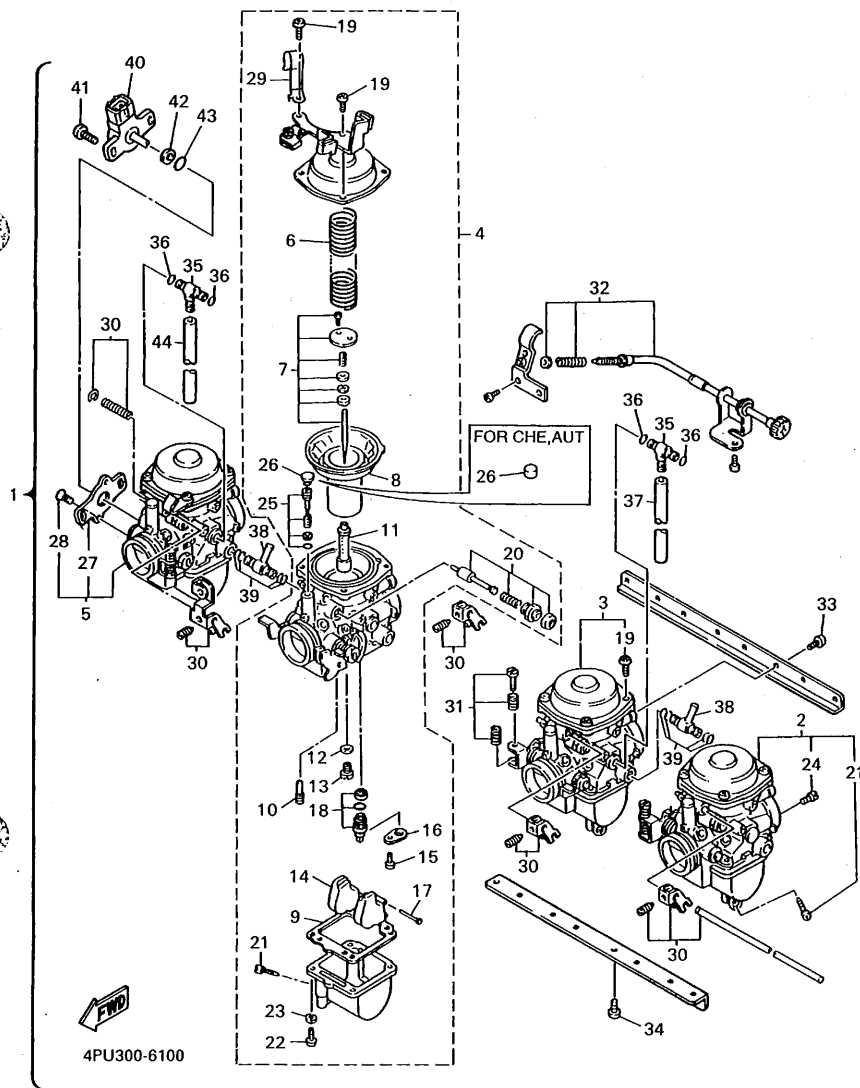
FIG. 9 INTAKE



4PU351-5090

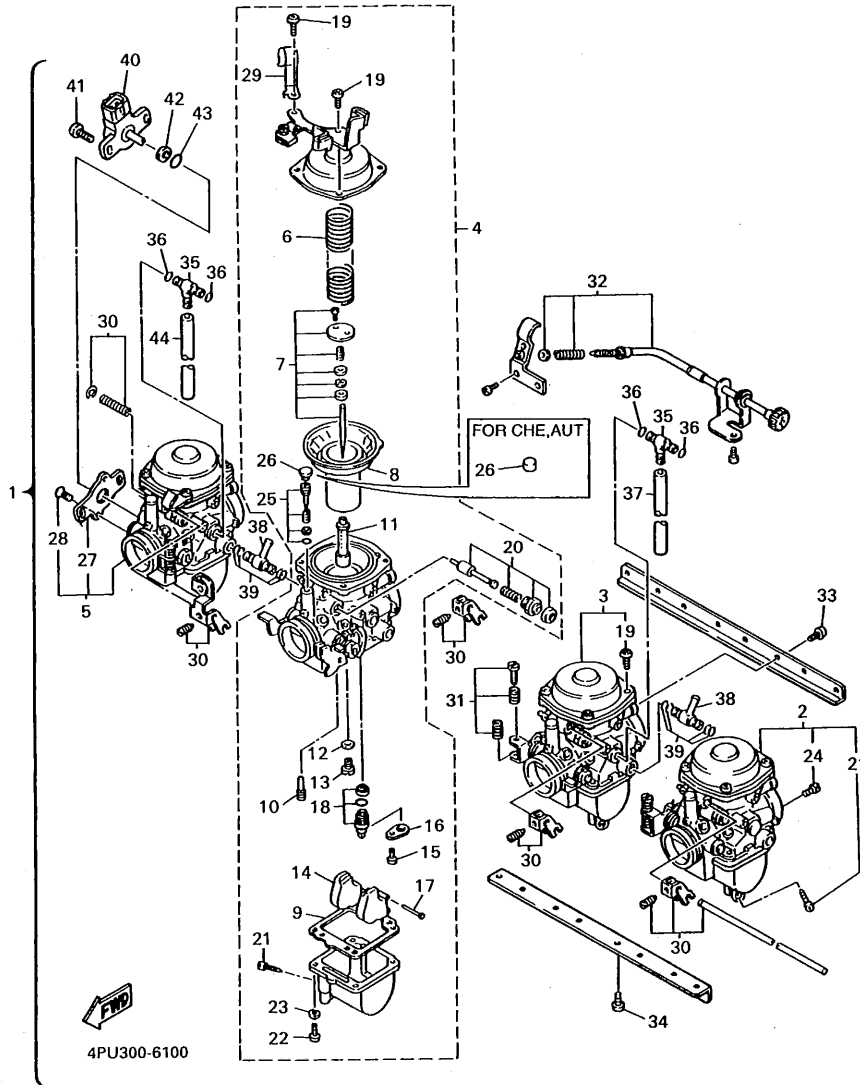
REF. NO.	PART NO.	DESCRIPTION	Q'TY	REMARKS
1	4KG-13586-00	JOINT, CARBURETOR 1	2	
2	4KG-13596-00	JOINT, CARBURETOR 2	2	
3	93210-40659	O-RING	4	
4	16G-13569-00	PLUG, BLIND	3	
5	90467-10039	CLIP	3	
6	91317-06020	BOLT	8	
7	1AE-13575-01	BAND	4	
8	4KG-14401-00	AIR CLEANER CASE ASSY	1	
9	31A-14453-00	JOINT, AIR CLEANER 1	2	
10	36Y-14463-00	JOINT, AIR CLEANER 2	2	
11	90460-58015	CLAMP, HOSE	4	
12	1HX-1443E-00	PIPE, DRAIN	1	
13	90445-11153	HOSE	1	
14	4X7-2149Y-00	FILTER ASSY	1	
15	90467-11106	CLIP	3	
16	4KG-14451-00	ELEMENT, AIR CLEANER	1	
17	4KG-14412-00	CAP, CLEANER CASE 1	1	
18	4KG-14437-00	DUCT	1	
19	97707-50525	SCREW, TAPPING	3	
20	97707-50525	SCREW, TAPPING	4	
21	34X-14457-00	SEAL	1	
22	31A-14419-00	PIPE	1	
23	31A-14435-00	GROMMET	1	
24	95807-06016	BOLT, FLANGE	3	

FIG. 10 CARBURETOR



REF. NO.	PART NO.	DESCRIPTION	Q'TY	REMARKS
1	4KG-14900-30	CARBURETOR ASSY	1	UR
	4RB-14900-10	CARBURETOR ASSY	1	UR FOR CHE, AUT
2	4KG-14901-30	..CARBURETOR ASSY 1	1	UR
	4RB-14901-10	..CARBURETOR ASSY 1	1	UR FOR CHE, AUT
3	4KG-14902-30	..CARBURETOR ASSY 2	1	UR
	4RB-14902-10	..CARBURETOR ASSY 2	1	UR FOR CHE, AUT
4	4KG-14903-30	..CARBURETOR ASSY 3	1	UR
	4RB-14903-10	..CARBURETOR ASSY 3	1	UR FOR CHE, AUT
5	4KG-14904-30	..CARBURETOR ASSY 4	1	UR
	4RB-14904-10	..CARBURETOR ASSY 4	1	UR FOR CHE, AUT
6	3Y6-14933-00	..SPRING, DIAPHRAGM	1	
7	4KG-1490J-00	..NEEDLE SET	1	UR
	4RB-1490J-01	..NEEDLE SET	1	UR FOR CHE, AUT
8	4KG-14940-00	..DIAPHRAGM ASSY	1	UR
	4RB-14940-00	..DIAPHRAGM ASSY	1	UR FOR CHE, AUT
9	3XW-14984-00	..GASKET, FLOAT CHAMBER	1	
10	4HR-14142-40	..JET, PILOT (# 40)	1	UR
	4HR-14142-37	..JET, PILOT (# 37.5)	1	UR FOR CHE, AUT
11	4KG-14141-92	..NOZZLE, MAIN	1	
12	137-14153-00	..WASHER, MAIN JET	1	
13	620-14231-19	..JET, MAIN (# 95)	1	
14	3H5-14985-00	..FLOAT	1	
15	98501-04006	..SCREW, PAN HEAD	1	
16	2H0-14146-00	..PLATE	1	
17	537-14186-00	..PIN, FLOAT	1	
18	3CF-14107-23	..NEEDLE VALVE SET	1	
19	98507-05010	..SCREW, PAN HEAD	4	
20	4KG-1410A-00	..STARTER SET	1	

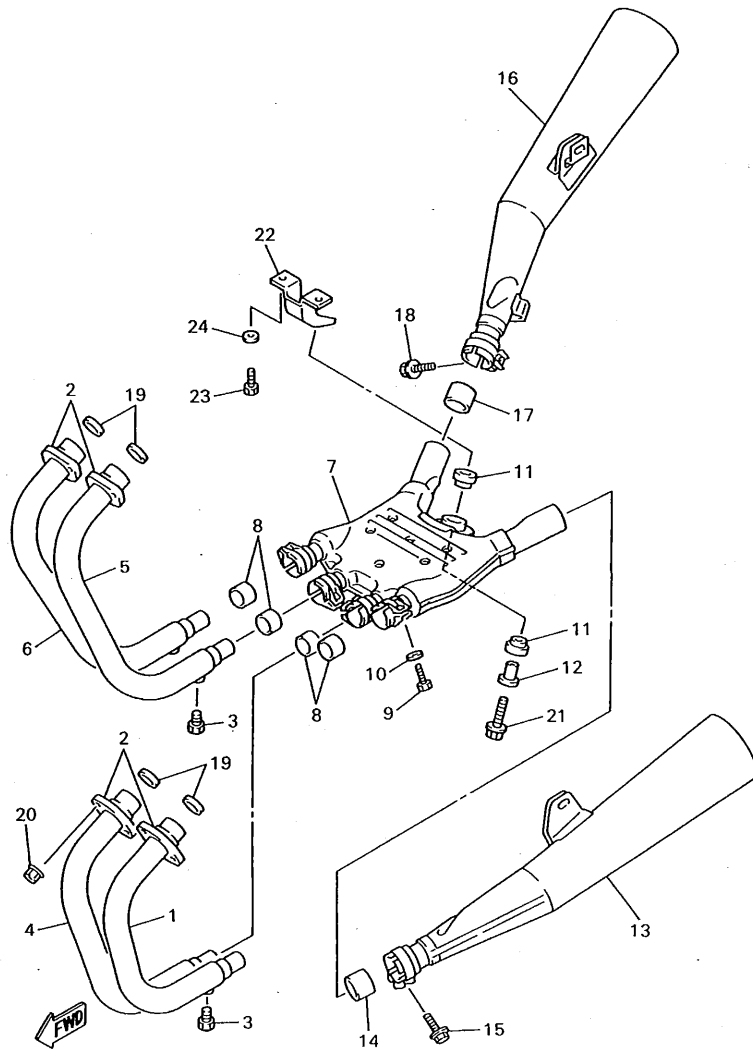
FIG. 10 CARBURETOR



4PU300-6100

REF. NO.	PART NO.	DESCRIPTION	Q'TY	REMARKS
21	12R-14191-00	..PLUG, DRAIN	1	
22	98507-05016	..SCREW, PAN HEAD	4	
23	92901-05100	..WASHER, SPRING	4	
24	3G2-14231-27	..JET, MAIN (#135)	1	UR
	3G2-14231-26-A0	..JET, MAIN (#130)	1	UR FOR CHE, AUT
25	4CC-14105-00	..PILOT SCREW SET	1	
26	22F-14991-00	..CAP	1	UR
	2RJ-14118-00	..CAP	1	UR FOR CHE, AUT
27	4KG-14995-00	..BRACKET	1	
28	98707-04008	..SCREW, FLAT HEAD	2	
29	4HM-14919-10	..CLIP	1	
30	4KG-1490L-10	..STARTER LEVER SET, 1	1	
31	3KW-1490K-00	..STOP SCREW SET	3	
32	4KG-14103-00	..THROTTLE SCREW SET	1	
33	98507-05010	..SCREW, PAN HEAD	8	
34	98503-06014	..SCREW, PAN HEAD	8	
35	17A-14251-00	..NIPPLE	2	
36	822-14147-00	..O-RING	4	
37	50H-14987-00	..HOSE	1	
38	36Y-14988-00	..PIPE, STARTER CONNECTING	2	
39	36Y-14147-00	..O-RING	8	
40	4KG-85885-00	..THROTTLE POSITION SENSOR ASSY	1	
41	4HM-14216-00	..SCREW	2	
42	4KG-14285-00	..WASHER	1	
43	4KG-14147-00	..O-RING	1	
44	4G0-14197-00	..PIPE	1	

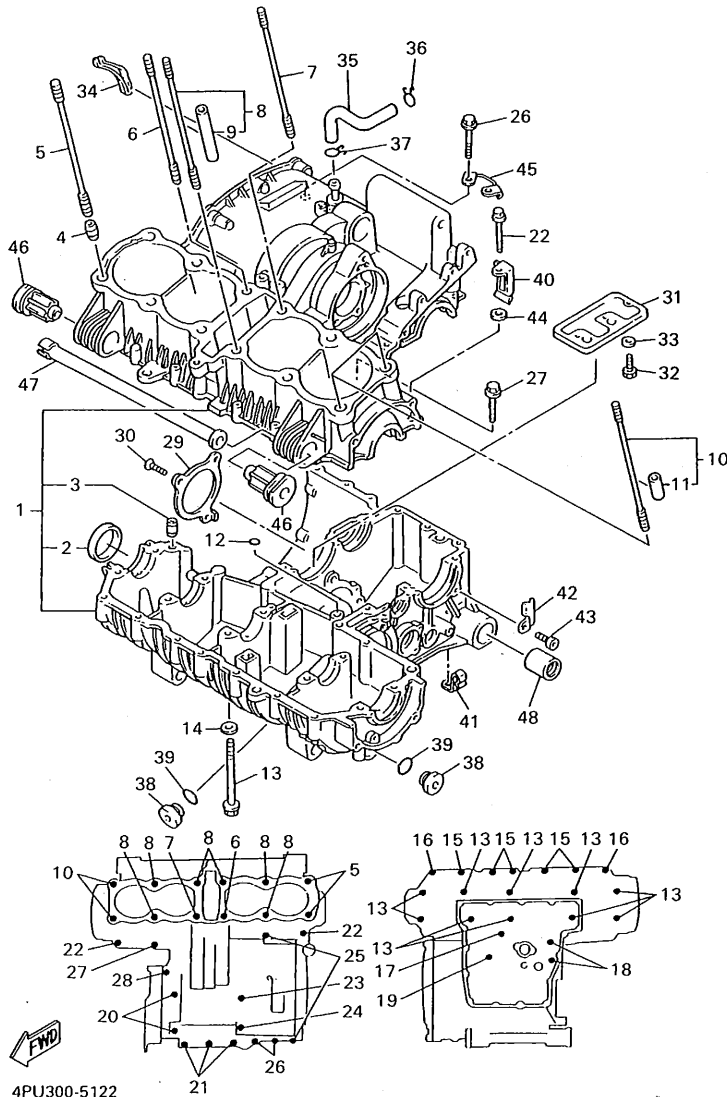
FIG. 11 EXHAUST



4PU351-5110

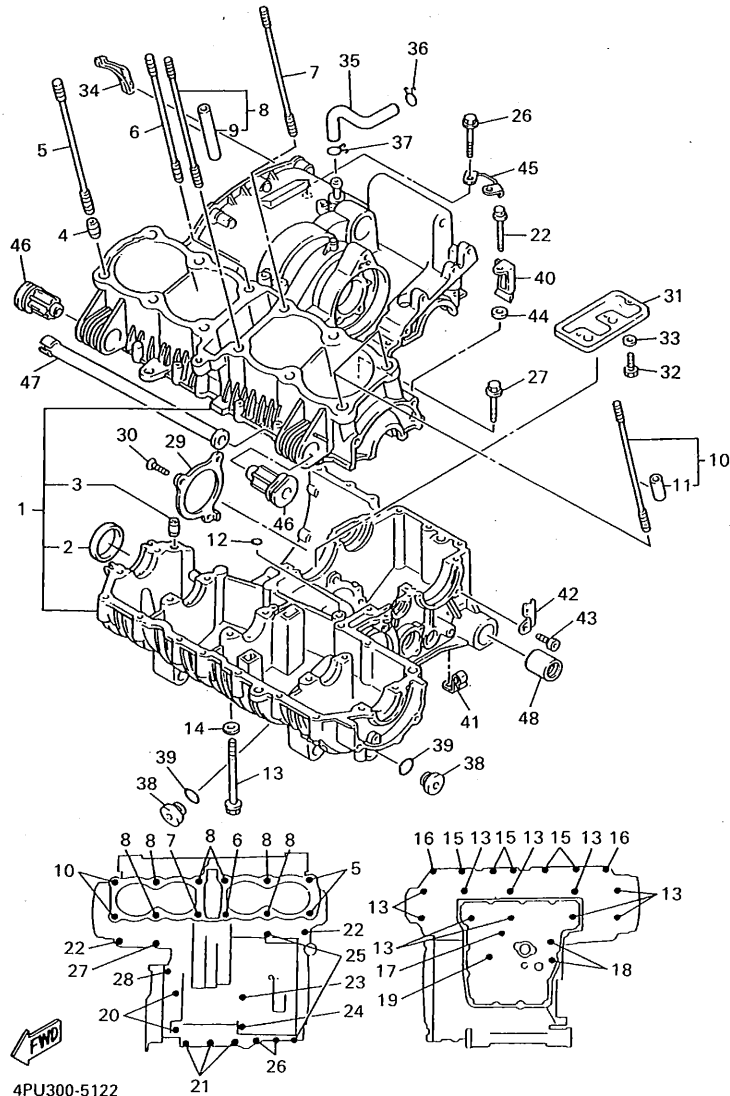
REF. NO.	PART NO.	DESCRIPTION	Q'TY	REMARKS
1	4KG-14611-00	PIPE, EXHAUST 1	1	
2	4KG-14612-00	NUT, RING	4	
3	90101-06576	BOLT	4	
4	4KG-14621-00	PIPE, EXHAUST 2	1	
5	4KG-14631-00	PIPE, EXHAUST 3	1	
6	4KG-14641-00	PIPE, EXHAUST 4	1	
7	4PU-14615-00	JOINT, EXHAUST 1	1	
8	3XW-14755-00	GASKET, SILENCER	4	
9	97024-08025	BOLT	4	
10	92990-08600	WASHER	4	
11	36Y-14747-00	DAMPER, MUFFLER	2	
12	4G0-14638-00	COLLAR	1	
13	4PU-14711-01	MUFFLER 1	1	
14	3XW-14714-00	GASKET, MUFFLER	1	
15	95814-08025	BOLT, FLANGE	1	
16	4PU-14721-01	MUFFLER 2	1	
17	3XW-14714-00	GASKET, MUFFLER	1	
18	95814-08025	BOLT, FLANGE	1	
19	4BE-14613-00	GASKET, EXHAUST PIPE	4	
20	95604-08200	NUT, SELF-LOCKING	8	
21	95807-10040	BOLT, FLANGE	1	
22	4KG-14791-00	STAY, MUFFLER	1	
23	97017-08025	BOLT	2	
24	92907-08600	WASHER	2	

FIG. 12 CRANKCASE



REF. NO.	PART NO.	DESCRIPTION	Q'TY	REMARKS
1	3XW-15100-02	CRANKCASE ASSY	1	
2	4H7-15167-10	PLUG, BLIND	1	
3	99510-12016	PIN, DOWEL	2	
4	99530-14016	PIN, DOWEL	2	
5	90116-10563	BOLT, STUD	2	
6	90116-10561	BOLT, STUD	1	
7	90116-10562	BOLT, STUD	1	
8	3XW-11363-01	BOLT, CYLINDER HOLDING 3	6	
9	3XW-1111J-00	PIPE 1	1	
10	3XW-11364-01	BOLT, CYLINDER HOLDING 4	2	
11	3XW-1112J-00	PIPE 2	1	
12	93210-07438	O-RING	1	
13	90105-080A3	BOLT, WASHER BASED	10	
14	90201-094G1	WASHER, PLATE	7	
15	95817-08045	BOLT, FLANGE	5	
16	90105-100A4	BOLT, WASHER BASED	2	
17	95817-06110	BOLT, FLANGE	1	
18	95817-06095	BOLT, FLANGE	2	
19	95817-06040	BOLT, FLANGE	1	
20	95817-08055	BOLT, FLANGE	2	
21	95817-10060	BOLT, FLANGE	3	
22	90105-060A2	BOLT, WASHER BASED	2	
23	95817-06125	BOLT, FLANGE	1	
24	95817-06070	BOLT, FLANGE	1	
25	90105-060A1	BOLT, WASHER BASED	2	
26	95817-06055	BOLT, FLANGE	2	
27	95817-06040	BOLT, FLANGE	1	
28	95817-06030	BOLT, FLANGE	1	

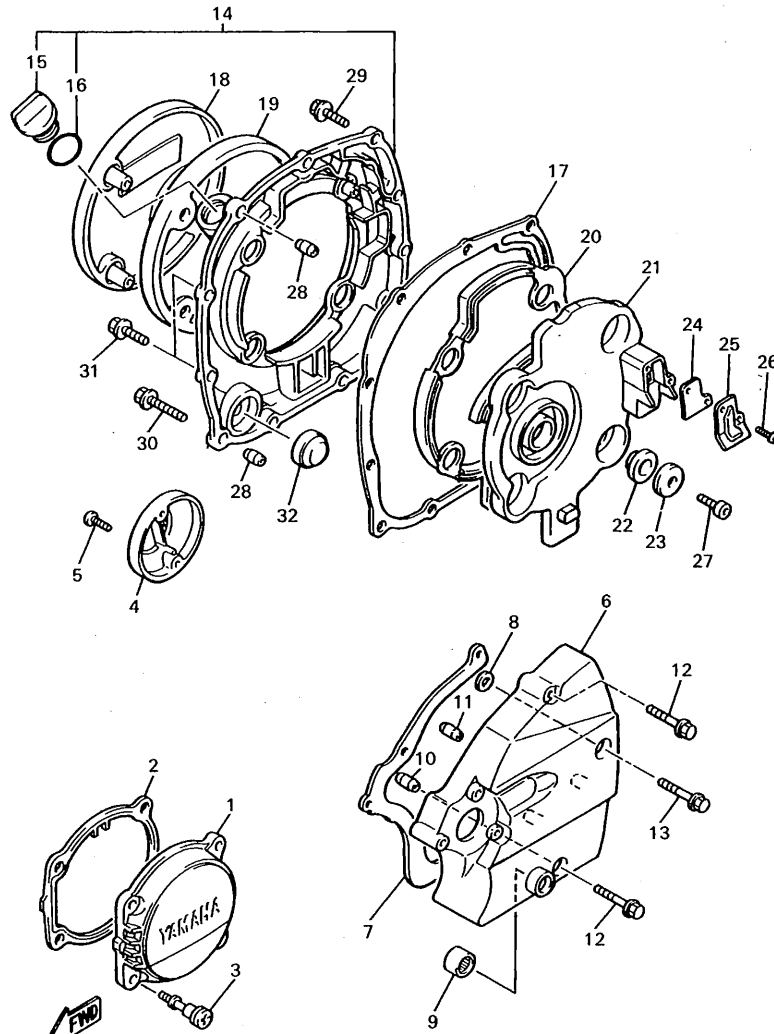
FIG. 12 CRANKCASE



4PU300-5122

REF. NO.	PART NO.	DESCRIPTION	Q'TY	REMARKS
29	36Y-15383-01	PLATE, BEARING COVER	1	
30	90151-06025	SCREW, COUNTERSUNK	3	
31	36Y-15412-00	PLATE, OIL GUIDE	1	
32	97007-05010	BOLT	3	
33	92907-05600	WASHER	3	
34	1TX-15365-00	GROMMET	1	
35	4KG-11166-00	PIPE, BREATHER 1	1	
36	90467-14015	CLIP	1	
37	90467-14015	CLIP	1	
38	4K0-15189-00	PLUG	3	
39	93210-20573	O-RING	3	
40	90465-10251	CLAMP	1	
41	90465-08252	CLAMP	2	
42	90465-08253	CLAMP	1	
43	91317-06010	BOLT	1	
44	92907-06600	WASHER	1	
45	90462-10145	CLAMP	1	
46	36Y-15336-00	DAMPER, ENGINE MOUNT 3	2	
47	36Y-15317-00	SPACER, ENGINE MOUNT	1	
48	93317-42060	BEARING, CYLINDRICAL	1	

FIG. 13 CRANKCASE COVER 1

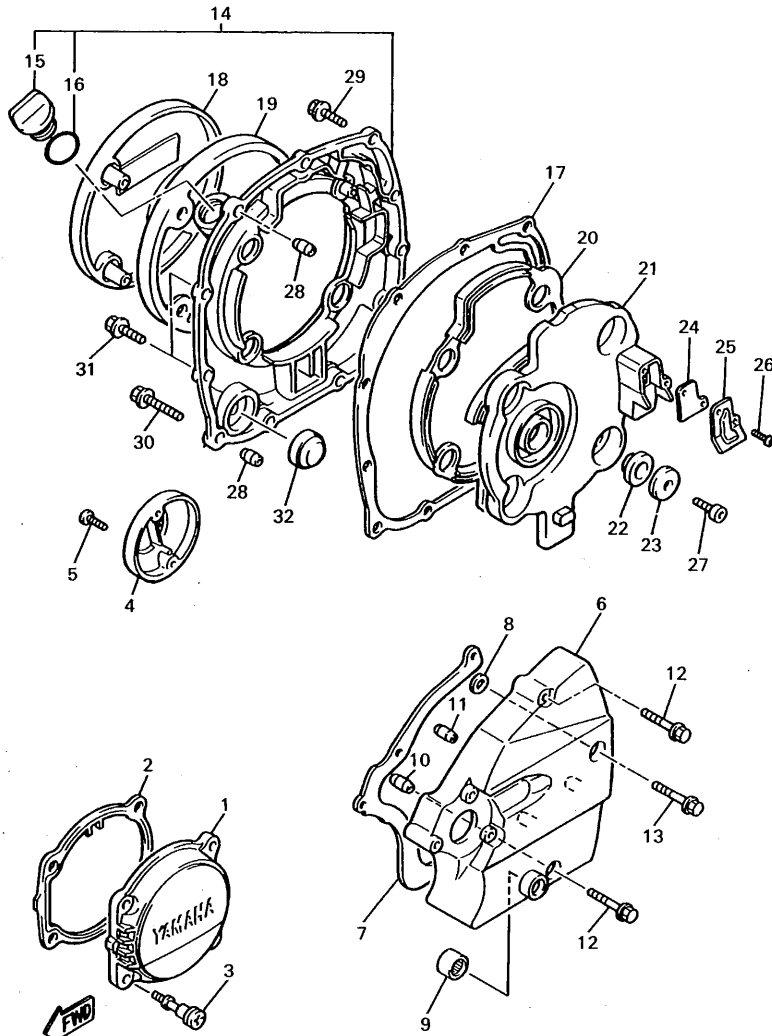


REF. NO.	PART NO.	DESCRIPTION	Q'TY	REMARKS
1	36Y-15416-00	COVER, OIL PUMP	1	
2	4KG-15449-00	RING, RUBBER	1	
3	4KG-15481-01	BOLT 1	4	
4	36Y-15426-00	COVER, OIL PUMP 2	1	
5	90154-05073	SCREW, BINDING	2	
6	4KG-15411-00	COVER, CRANKCASE 1	1	
7	4CR-15451-00	GASKET, CRANKCASE COVER 1	1	
8	4CR-15467-00	GASKET	1	
9	93317-21236	BEARING, CYLINDRICAL	1	
10	99530-10014	PIN, DOWEL	1	
11	99510-08016	PIN, DOWEL	1	
12	90105-06792	BOLT, WASHER BASED	2	
13	90105-06798	BOLT, WASHER BASED	1	
14	3XW-W1543-00	CRANKCASE COVER ASSY 2	1	
15	3F9-15362-00	•PLUG, OIL LEVEL	1	
16	93210-27778	•O-RING	1	
17	4CR-15461-00	GASKET, CRANKCASE COVER 2	1	
18	36Y-15417-01	COVER, CAP	1	
19	36Y-15449-00	RING, RUBBER	1	
20	1TX-15367-00	GROMMET	1	
21	1TX-15346-00	BREATHER 1	1	
22	4H7-15486-00	GROMMET	4	
23	90209-06096	WASHER	4	
24	4CR-15374-00	GASKET, BREATHER	1	
25	1TX-15333-00	COVER	1	
26	90157-05095	SCREW, PAN HEAD	2	
27	97027-06012	BOLT	4	
28	99530-10014	PIN, DOWEL	2	

4KG010-4130



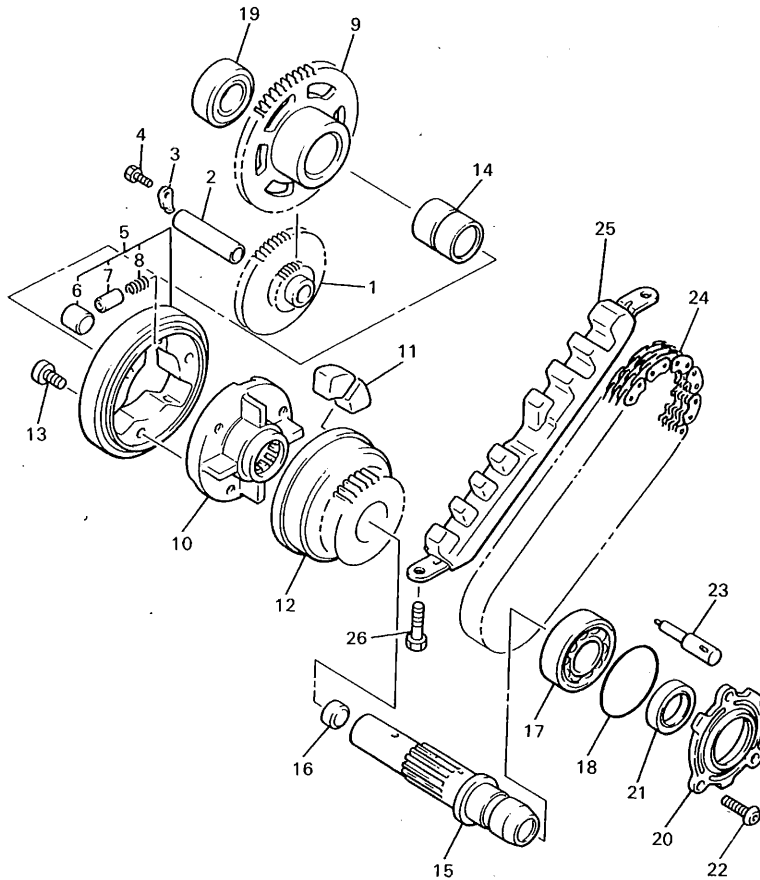
FIG. 13 CRANKCASE COVER 1



REF. NO.	PART NO.	DESCRIPTION	Q'TY	REMARKS
29	90105-06790	BOLT, WASHER BASED	7	
30	90105-06799	BOLT, WASHER BASED	2	
31	90105-060A0	BOLT, WASHER BASED	2	
32	2H7-15361-00	GAUGE, LEVEL	1	

4KG010-4130

FIG. 14 STARTER

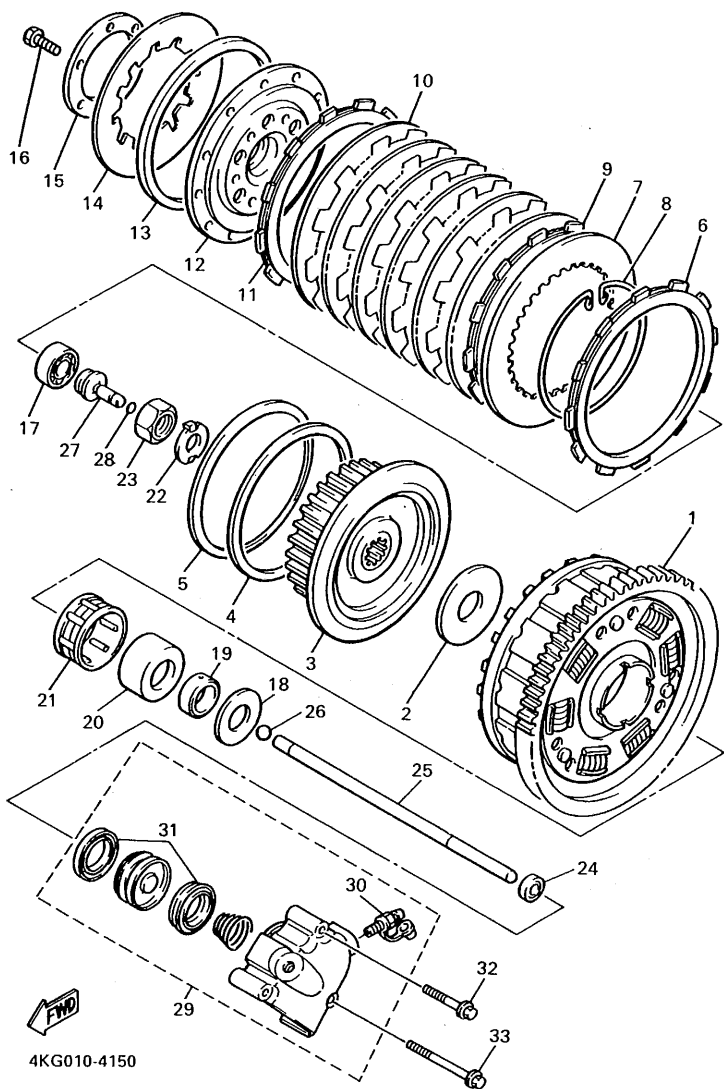


REF. NO.	PART NO.	DESCRIPTION	Q'TY	REMARKS
1	36Y-15512-01	GEAR, IDLER 1 (12/55T)	1	
2	36Y-15521-01	SHAFT 1	1	
3	2H7-15531-00	PLATE, STOPPER	1	
4	97027-06012	BOLT	1	
5	36Y-15580-02	STARTER CLUTCH OUTER ASSY	1	
6	93615-17125	•PIN, DOWEL	3	
7	1J7-15583-01	•CAP, STARTER CLUTCH SPRING	3	
8	90501-05764	•SPRING, COMPRESSION	3	
9	36Y-15517-01	GEAR, IDLER 2 (45T)	1	
10	12R-15524-00	WHEEL, STARTER	1	
11	4H7-16155-01	ABSORBER 1	4	
12	36Y-15519-00	SPROCKET, STARTER 2	1	
13	91317-08016	BOLT	3	
14	90387-201L2	COLLAR	1	
15	3CV-15522-00	SHAFT 2	1	
16	90331-15039	PLUG	1	
17	93306-20545	BEARING	1	
18	93210-47440	O-RING	1	
19	93306-00426	BEARING	1	
20	36Y-15163-00	HOUSING, BEARING 1	1	
21	93102-25253	OIL SEAL	1	
22	90149-06228	SCREW	3	
23	36Y-13454-00	NOZZLE	1	
24	4FM-11456-00	CHAIN, PRIMARY	1	
25	36Y-11474-00	GUIDE, UPPER	1	
26	97017-06016	BOLT	2	



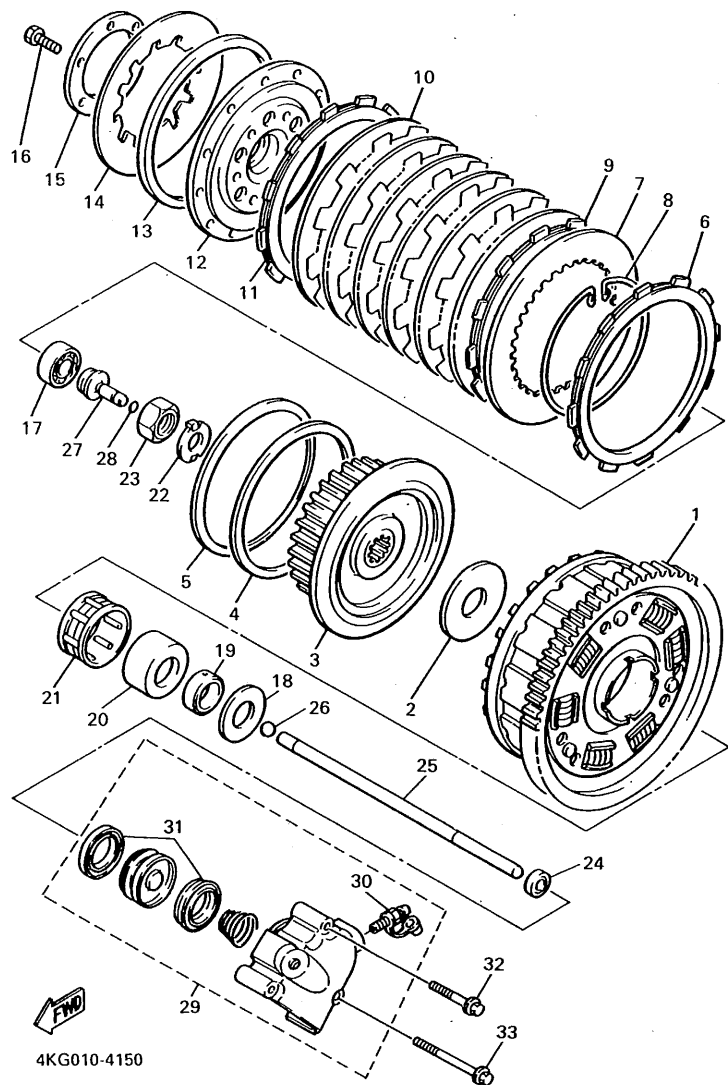
4KG010-4140

FIG. 15 CLUTCH



REF. NO.	PART NO.	DESCRIPTION	Q'TY	REMARKS
1	1TX-16150-01	PRIMARY DRIVEN GEAR COMP.	1	
2	36Y-16154-00	PLATE, THRUST 1	1	
3	36Y-16371-00	BOSS, CLUTCH	1	
4	36Y-16384-00	PLATE, SEAT	1	
5	36Y-16383-00	SPRING, CLUTCH BOSS	1	
6	36Y-16331-00	PLATE, FRICTION 2	1	
7	2H7-16325-00	PLATE, CLUTCH 2	1	
8	2H7-16385-00	RING, CLUTCH BOSS	1	
9	341-16321-13	PLATE, FRICTION	6	
10	2H7-16325-00	PLATE, CLUTCH 2	6	
11	36Y-16331-00	PLATE, FRICTION 2	1	
12	36Y-16351-00	PLATE, PRESSURE 1	1	
13	36Y-16335-00	HOUSING, SPRING	1	
14	36Y-16334-00	SPRING, CLUTCH 2	1	
15	1TX-16352-00	PLATE, PRESSURE 2	1	
16	97017-06016	BOLT	6	
17	93306-00315	BEARING (6003SH2C4)	1	
18	90201-286H8	WASHER, PLATE	1	
19	90387-284K1	COLLAR	1	
20	36Y-16181-00	SPACER 1	1	
21	93310-350M3	BEARING, CYLINDRICAL	1	
22	90215-25218	WASHER, LOCK	1	
23	90170-20323	NUT	1	
24	93109-08061	OIL SEAL	1	
25	4KG-16357-00	ROD, PUSH 2	1	
26	93511-32027	BALL	1	
27	4KG-16356-00	ROD, PUSH 1	1	
28	93210-06632	O-RING	1	

FIG. 15 CLUTCH



4KG010-4150

REF. NO.	PART NO.	DESCRIPTION	Q'TY	REMARKS
29	36Y-16381-11	PUSH LEVER COMP.	1	
30	36Y-W0048-00	.BLEED SCREW KIT	1	
31	26H-W0098-00	.PUSH LEVER SEAL KIT	1	
32	90105-06792	BOLT, WASHER BASED	1	
33	90109-063G3	BOLT	2	

FIG. 16 TRANSMISSION

REF. NO.	PART NO.	DESCRIPTION	Q'TY	REMARKS
1	4KG-W1741-00	MAIN AXLE ASSY	1	
2	93306-36401	BEARING	1	
3	4CC-17141-00	GEAR, 4TH PINION (24T)	1	
4	90209-25196	WASHER	1	
5	93440-28062	CIRCLIP	1	
6	1TX-17131-00	GEAR, 3RD PINION (21T)	1	
7	90201-226H9	WASHER, PLATE	1	
8	1TX-17151-00	GEAR, 5TH PINION (26T)	1	
9	3CV-17121-00	GEAR, 2ND PINION (18T)	1	
10	90387-220R2	COLLAR	1	
11	93306-30434	BEARING	1	
12	4KG-17421-00	AXLE, DRIVE	1	
13	1TX-17211-00	GEAR, 1ST WHEEL (40T)	1	
14	90201-257H0	WASHER, PLATE	2	
15	4CC-17241-00	GEAR, 4TH WHEEL (31T)	1	
16	93440-30077	CIRCLIP	1	
17	90209-27192	WASHER	1	
18	1TX-17231-00	GEAR, 3RD WHEEL (33T)	1	
19	90201-307H1	WASHER, PLATE	1	
20	1TX-17251-00	GEAR, 5TH WHEEL (29T)	1	
21	93440-34025	CIRCLIP	1	
22	90209-32231	WASHER	1	
23	3CV-17221-00	GEAR, 2ND WHEEL (36T)	1	
24	93305-20605	BEARING	1	
25	93102-40330	OIL SEAL	1	
26	93210-30660	O-RING	1	
27	90387-3003P	COLLAR	1	
28	4KG-17460-00	SPROCKET, DRIVE (17T)	1	

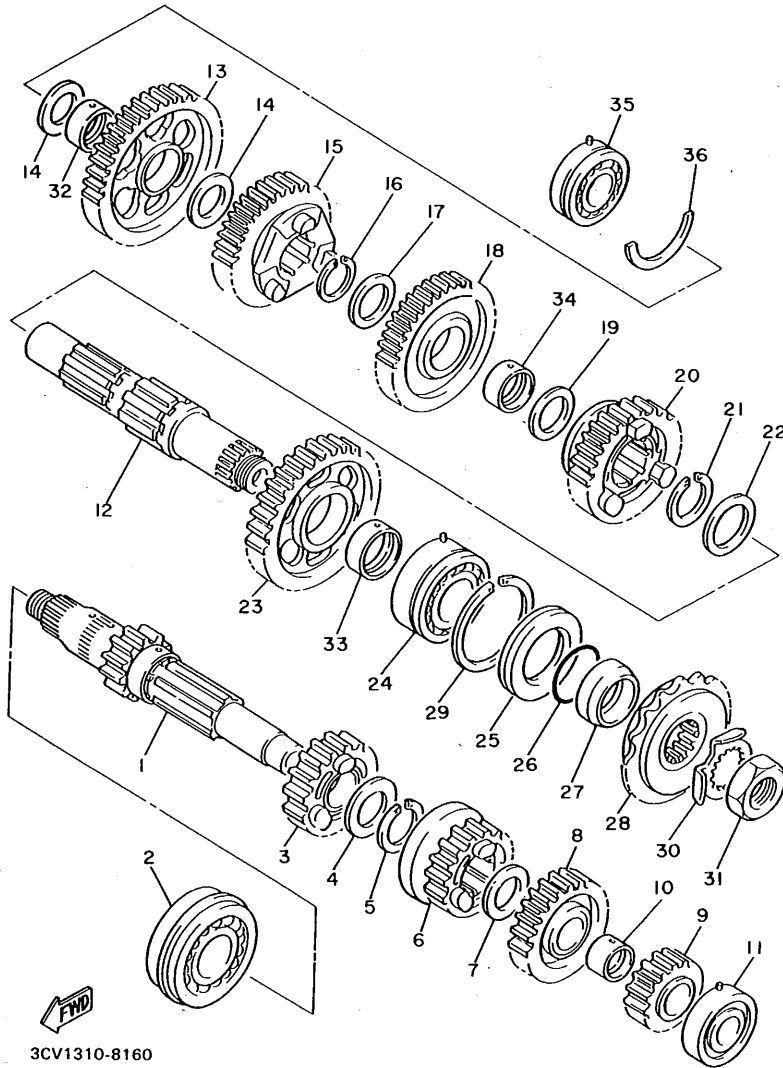
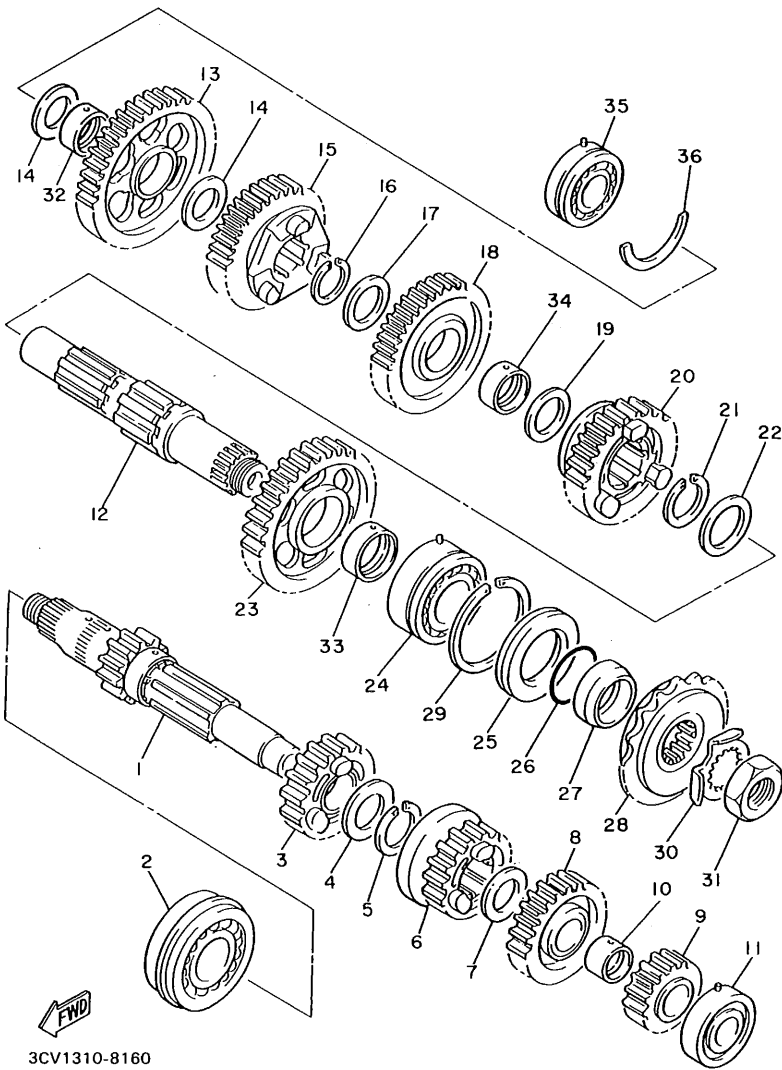


FIG. 16 TRANSMISSION

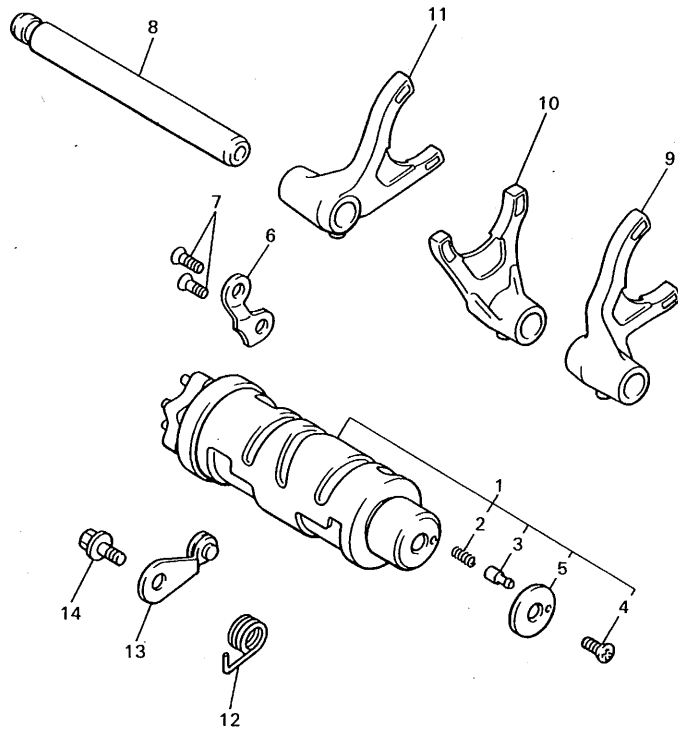


REF. NO.	PART NO.	DESCRIPTION	Q'TY	REMARKS
29	93440-62032	CIRCLIP	1	
30	90215-26241	WASHER, LOCK	1	
31	90179-22063	NUT	1	
32	90387-250R3	COLLAR	1	
33	90387-350R5	COLLAR	1	
34	90387-300R4	COLLAR	1	
35	93306-20561	BEARING	1	
36	93440-52118	CIRCLIP	1	

3CV1310-8160

**C9**

FIG. 17 SHIFT CAM • FORK



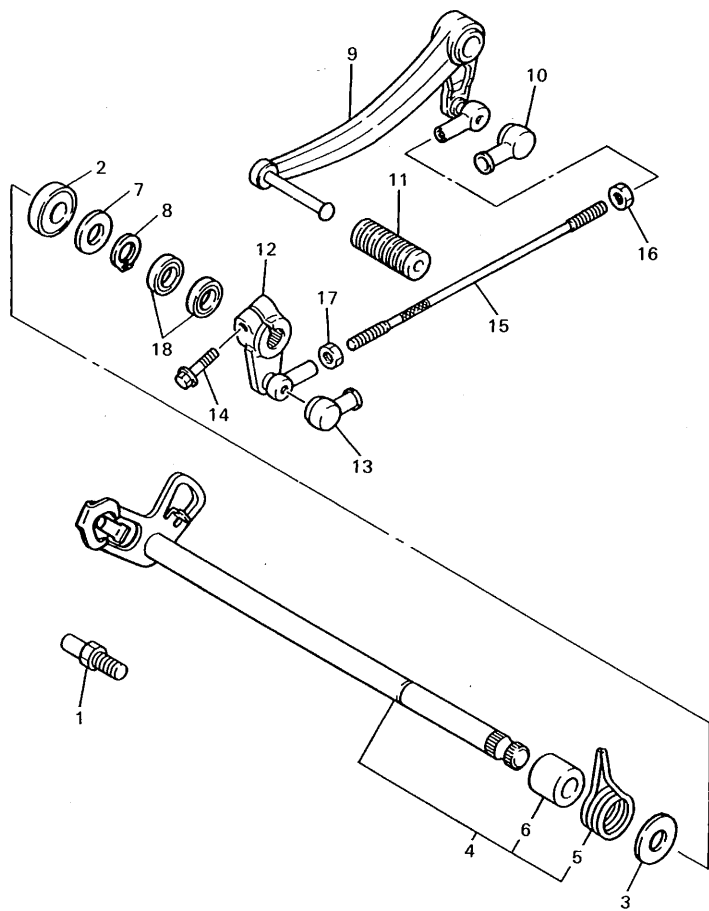
REF. NO.	PART NO.	DESCRIPTION	Q'TY	REMARKS
1	3XW-18540-00	SHIFT CAM ASSY	1	
2	90501-06022	•SPRING, COMPRESSION	1	
3	278-18542-00	•POINT, NEUTRAL	1	
4	98707-05012	•SCREW, FLAT HEAD	1	
5	278-18566-00	•PLATE, SIDE 2	1	
6	36Y-18562-00	PLATE, STOPPER 2	1	
7	98707-06016	SCREW, FLAT HEAD	2	
8	4BR-18531-00	BAR, SHIFT FORK GUIDE 1	1	
9	3XW-18511-00	FORK, SHIFT 1	1	
10	4KG-18512-00	FORK, SHIFT 2	1	
11	3XW-18513-00	FORK, SHIFT 3	1	
12	90508-23707	SPRING, TORSION	1	
13	36Y-18140-00	STOPPER LEVER ASSY	1	
14	90109-063F7	BOLT	1	



4KG010-4170

**C10**

FIG. 18 SHIFT SHAFT



REF. NO.	PART NO.	DESCRIPTION	Q'TY	REMARKS
1	4G0-18127-00	STOPPER, SCREW	1	
2	93102-12106	OIL SEAL (SD 12-22-5 HS)	1	
3	90201-12588	WASHER, PLATE	1	
4	4KG-18101-01	SHIFT SHAFT ASSY	1	
5	90508-32682	SPRING, TORSION	1	
6	90387-114K8	COLLAR	1	
7	90201-12575	WASHER, PLATE	1	
8	99006-10600	CIRCLIP	1	
9	4KG-18111-00	PEDAL, SHIFT	1	
10	2H9-18154-00	COVER, DUST	1	
11	132-18113-01	COVER, SHIFT PEDAL	1	
12	2GH-18112-01	ARM, SHIFT	1	
13	2H9-18154-00	COVER, DUST	1	
14	95824-06020	BOLT, FLANGE	1	
15	2GV-18115-00	ROD, SHIFT	1	
16	90170-06228	NUT(COUNTER CLOCKWISE)	1	
17	95304-06700	NUT	1	
18	93109-12053	OIL SEAL (SDO 12/18/4-1)	2	

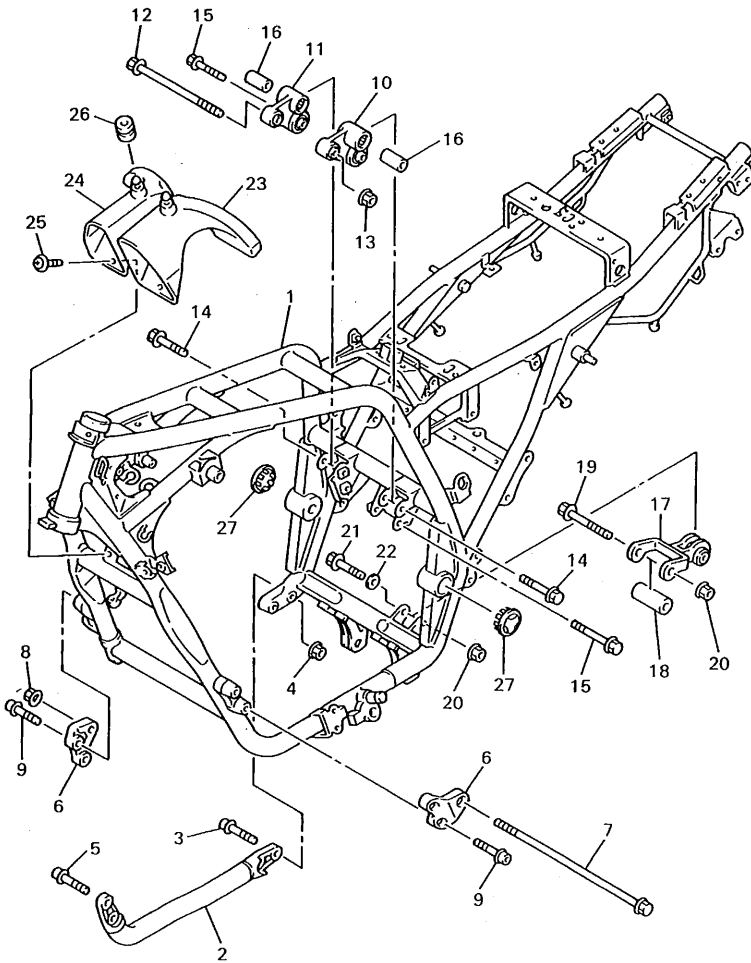


4KG010-4180



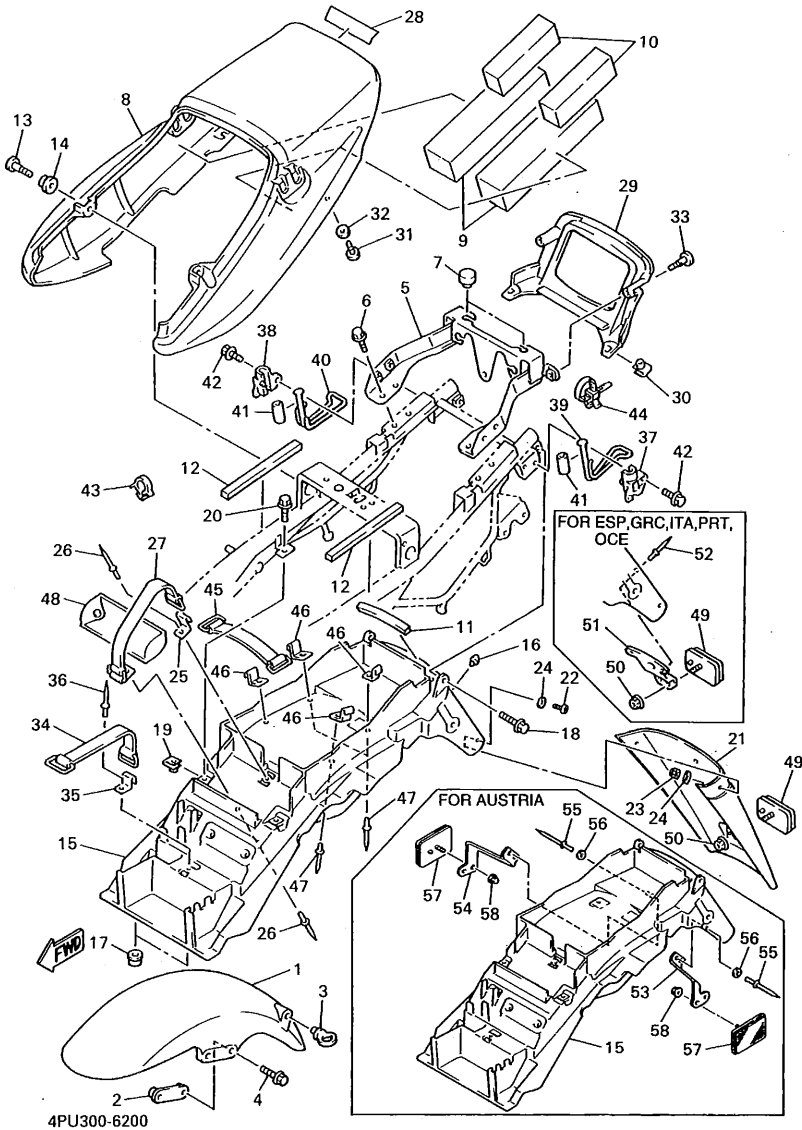
FIG. 19 FRAME

REF. NO.	PART NO.	DESCRIPTION	Q'TY	REMARKS
1	4PU-21110-00-33	FRAME COMP.	1	YAMAHA BLACK
2	4KG-21150-00-33	DOWN TUBE COMP.2	1	YAMAHA BLACK
3	90110-08232	BOLT, HEXAGON SOCKET HEAD	2	
4	95617-08200	NUT, FLANGE	2	
5	90110-08231	BOLT, HEXAGON SOCKET HEAD	2	
6	4KG-21315-01	STAY, ENGINE 2	2	
7	90105-10313	BOLT, WASHER BASED	1	
8	90179-10658	NUT	1	
9	90110-08199	BOLT, HEXAGON SOCKET HEAD	4	
10	4KG-2140X-00	ENGINE BRACKET SUB-COMP. 1	1	
11	4KG-2140Y-00	ENGINE BRACKET SUB-COMP. 2	1	
12	90105-10300	BOLT, WASHER BASED	1	
13	90179-10658	NUT	1	
14	90105-10402	BOLT, WASHER BASED	2	
15	90105-12425	BOLT, WASHER BASED	2	
16	90387-1003V	COLLAR	2	
17	4KG-21400-00	ENGINE BRACKET COMP.	1	
18	90387-1003W	COLLAR	1	
19	90105-10609	BOLT, WASHER BASED	1	
20	90179-10658	NUT	2	
21	90105-10323	BOLT, WASHER BASED	1	
22	92907-10200	WASHER, PLAIN	1	
23	4KG-2838N-00	DUCT 1	1	
24	4KG-2838R-00	DUCT 2	1	
25	90159-06058	SCREW, WITH WASHER	2	
26	90480-13567	GROMMET	2	
27	4BH-2219X-00	COVER	2	



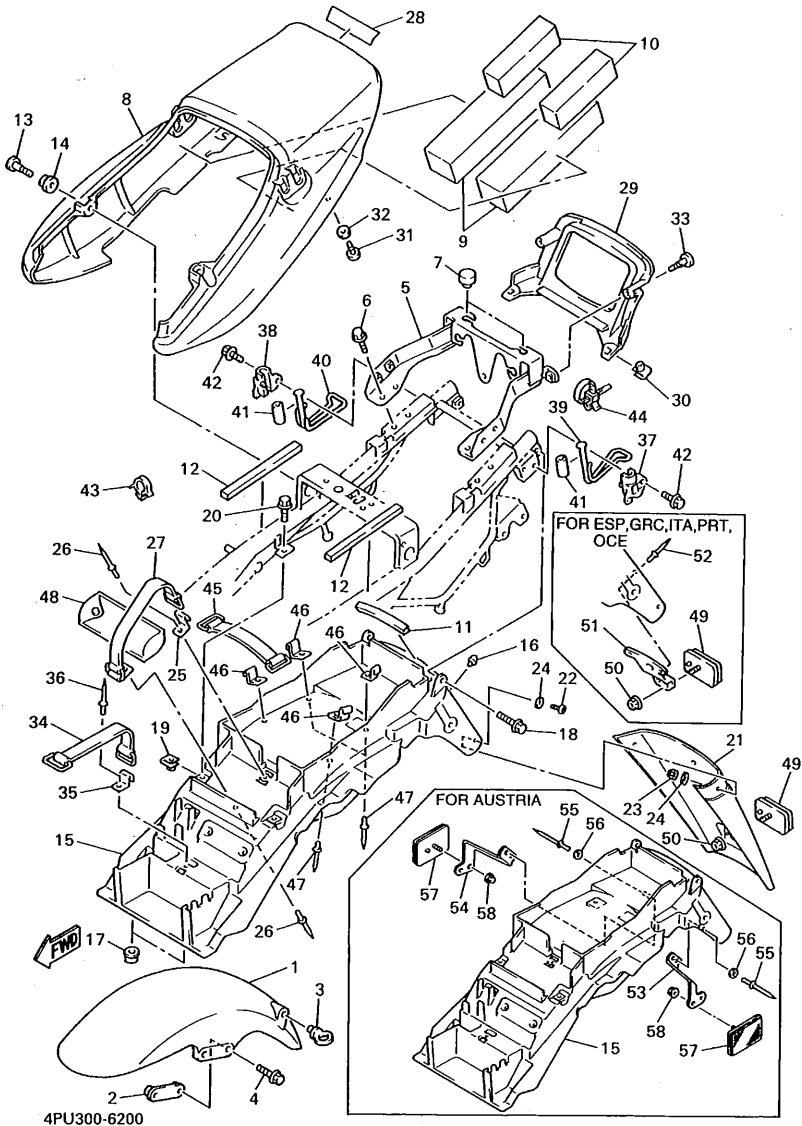
4PU351-5190

FIG. 20 FENDER



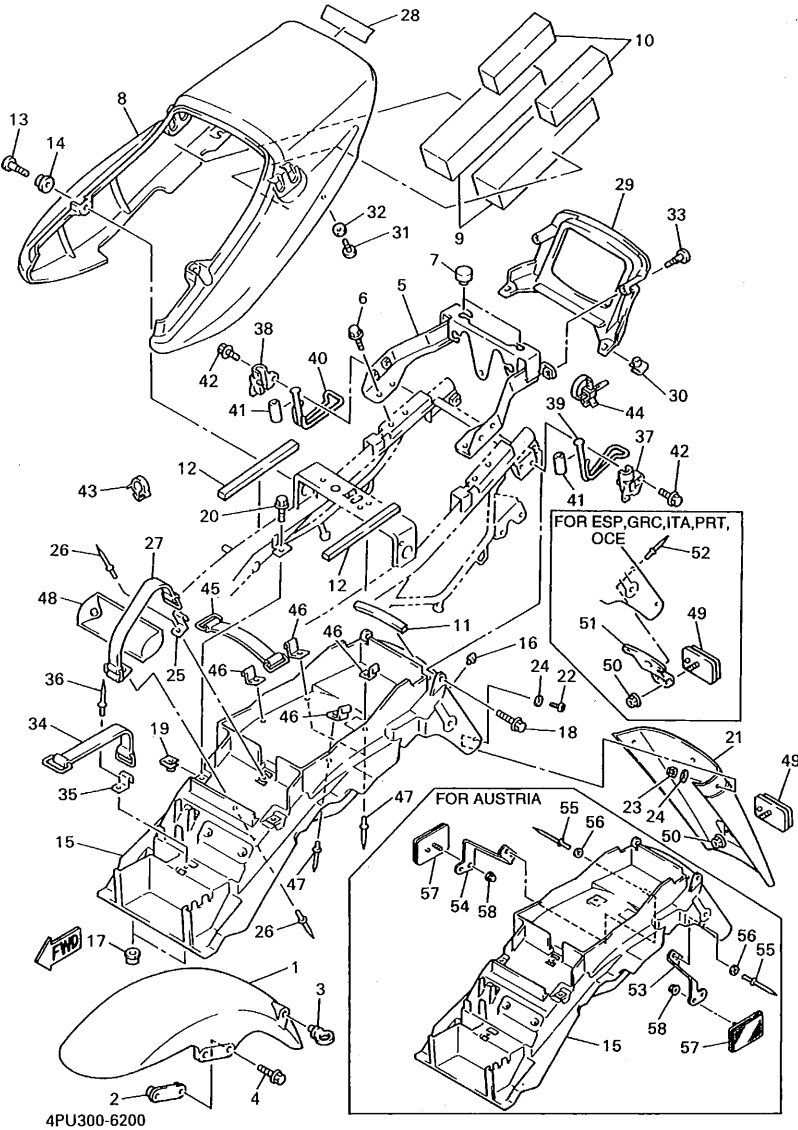
REF. NO.	PART NO.	DESCRIPTION	Q'TY	REMARKS
1	4KG-21511-00-P0	FENDER, FRONT	1	UR DEEP RED COCKTAIL 2 UR BLACK 2
	4KG-21511-00-4B	FENDER, FRONT	1	
2	4KG-21512-00	BRACKET, FENDER	2	
3	1A8-21518-00	HOLDER, CABLE	1	
4	95024-06025	BOLT, FLANGE	4	
5	4PU-2117E-00	BRACKET, TAILLIGHT	1	
6	95817-08012	BOLT, FLANGE	4	
7	22W-24741-00	PAD, SEAT	2	
8	4KG-21651-00-P0	COVER, REAR FENDER	1	UR DEEP RED COCKTAIL 2 UR BLACK 2
	4KG-21651-00-4B	COVER, REAR FENDER	1	
9	4KG-21779-00	DAMPER, LOCATING 2	2	
10	4KG-21778-00	DAMPER, LOCATING 1	2	
11	4KG-2177N-00	DAMPER, LOCATING 4	1	
12	4HM-2139X-00	DAMPER	2	
13	90150-06036	SCREW, ROUND HEAD	2	
14	90480-13398	GROMMET	2	
15	4PU-21611-00	FENDER, REAR	1	UR
	4RB-21611-00	FENDER, REAR	1	UR FOR AUSTRIA
16	4G0-21639-00	DAMPER 2	1	
17	90480-13398	GROMMET	2	
18	90109-063F1	BOLT	2	
19	90183-06053	NUT, SPRING	2	
20	95807-06016	BOLT, FLANGE	2	
21	3GM-21621-00	FLAP	1	
22	90149-04278	SCREW	4	
23	95607-04100	NUT, U	4	
24	90201-04018	WASHER, PLATE	8	
25	4HM-2162A-00	HOOK	1	

FIG. 20 FENDER



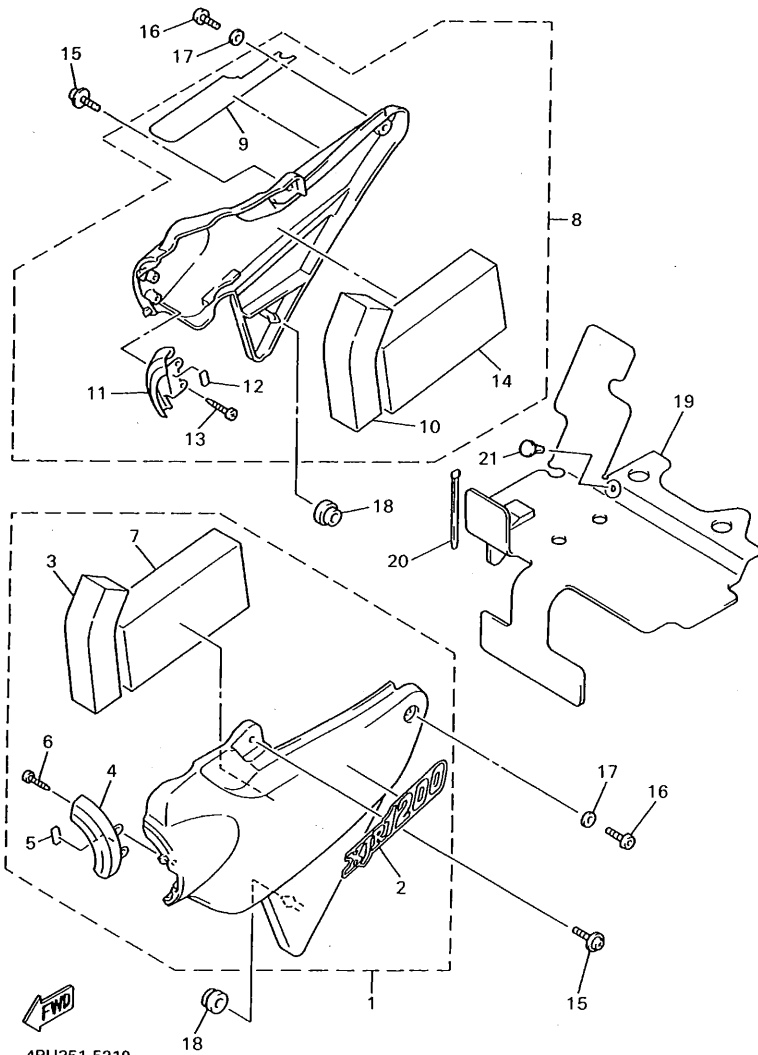
REF. NO.	PART NO.	DESCRIPTION	Q'TY	REMARKS
26	90267-40076	RIVET, BLIND	2	
27	4HM-82131-00	BAND, BATTERY	1	
28	99237-00100	EMBLEM, YAMAHA	1	
29	4PU-2163F-00	COVER, REAR FENDER 3	1	
30	90183-05061	NUT, SPRING	2	
31	90154-05059	SCREW, BINDING	2	
32	90202-06113	WASHER, PLATE	2	
33	90154-05059	SCREW, BINDING	2	
34	4J2-82131-01	BAND, BATTERY	1	
35	4HM-2162A-00	HOOK	1	
36	90267-40076	RIVET, BLIND	1	
37	4KG-21331-00	HOOK, SIDE COVER 1	1	
38	4KG-21332-00	HOOK, SIDE COVER 2	1	
39	4KG-21654-00	WIRE	1	
40	4KG-21664-00	WIRE, 2	1	
41	4KG-21639-00	DAMPER 2	2	
42	95807-06016	BOLT, FLANGE	2	
43	90464-15157	CLAMP	1	
44	90464-12036	CLAMP	1	
45	120-82131-00	BAND, BATTERY	2	
46	36F-28379-00	HOOK	4	
47	90267-40076	RIVET, BLIND	4	
48	4KG-28100-00	TOOL KIT	1	
49	3G1-85130-01	REAR REFLECTOR ASSY	1	UR
	4CF-85130-00	REAR REFLECTOR ASSY	1	UR FOR OCEANIA
50	95707-05500	NUT, FLANGE	1	
51	4KG-85132-00	BRACKET, REFLECTOR 1	1	FOR ESP, GRC, ITA, PRT, OCE
52	90267-40076	RIVET, BLIND	2	FOR ESP, GRC, ITA, PRT, OCE
53	3LK-21688-00	BRACKET, REAR STAY	1	FOR AUSTRIA

FIG. 20 FENDER



REF. NO.	PART NO.	DESCRIPTION	Q'TY	REMARKS
54	3LK-21689-00	BRACKET, REAR STAY 2	1	FOR AUSTRIA
55	90267-40076	RIVET, BLIND	4	FOR AUSTRIA
56	90201-04018	WASHER, PLATE	4	FOR AUSTRIA
57	23V-85110-00	REFLECTOR ASSY	2	FOR AUSTRIA
58	95707-05500	NUT, FLANGE	2	FOR AUSTRIA

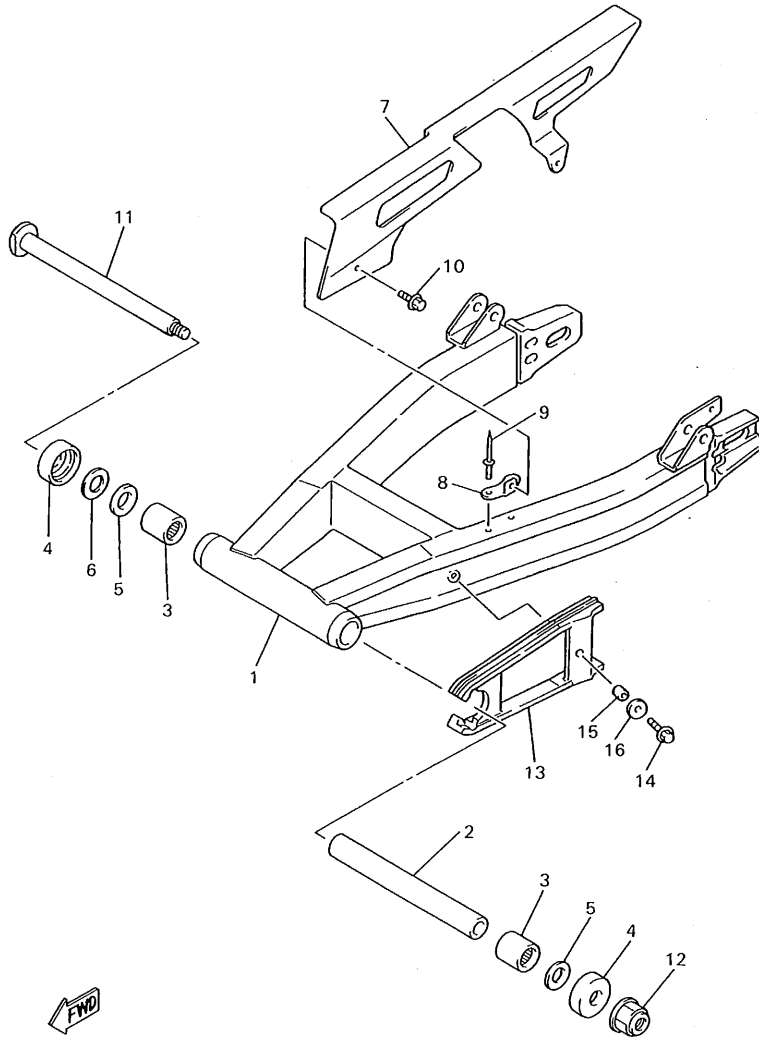
FIG. 21 SIDE COVER



4PU351-5210

REF. NO.	PART NO.	DESCRIPTION	Q'TY	REMARKS
1	4KG-Y2171-10-0X	COVER, SIDE 1	1	UR BLACK 2
	4KG-Y2171-10-1X	COVER, SIDE 1	1	UR DEEP RED COCKTAIL 2
2	4KG-21781-00	•EMBLEM 1	1	
3	4KG-21717-00	•DAMPER	1	
4	4KG-2172A-00	•PANEL 1	1	
5	51Y-21639-00	•DAMPER 2	1	
6	97707-50510	•SCREW, TAPPING	2	
7	4KG-21746-00	•DAMPER	1	
8	4KG-Y2172-10-0X	COVER, SIDE 2	1	UR BLACK 2
	4KG-Y2172-10-1X	COVER, SIDE 2	1	UR DEEP RED COCKTAIL 2
9	4KG-21782-00	•EMBLEM 2	1	
10	4KG-21717-00	•DAMPER	1	
11	4KG-2172F-00	•PANEL 2	1	
12	51Y-21639-00	•DAMPER 2	1	
13	97707-50510	•SCREW, TAPPING	2	
14	4KG-21746-00	•DAMPER	1	
15	90159-06059	SCREW, WITH WASHER	2	
16	90149-06298	SCREW	2	
17	90202-06113	WASHER, PLATE	2	
18	90480-01558	GROMMET	2	
19	4KG-21732-00	SEAL 1	1	
20	90464-13080	CLAMP	1	
21	90338-06233	PLUG	1	

FIG. 22 REAR ARM

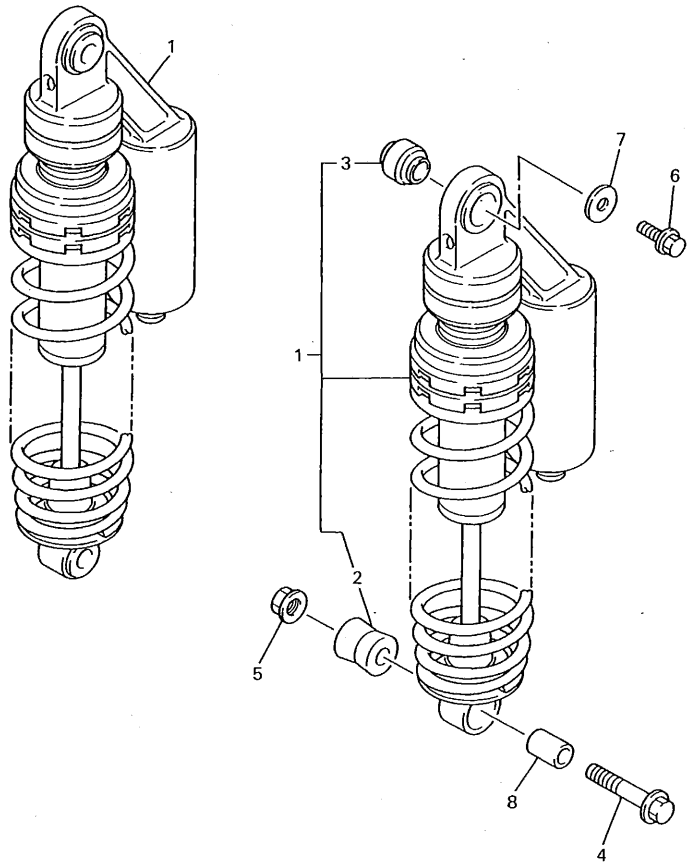


REF. NO.	PART NO.	DESCRIPTION	Q'TY	REMARKS
1	4KG-22110-00	REAR ARM COMP.	1	
2	3FV-22184-00	BUSH	1	
3	93315-42523	BEARING, CYLINDRICAL	2	
4	3FV-22128-00	COVER, THRUST 1	2	
5	3XV-22127-00	SHIM	2	
6	90201-203F0	WASHER, PLATE	1	UN
7	4KG-22311-00	CASE, CHAIN	1	
8	4KG-22321-00	STAY, CHAIN CASE 1	1	
9	90267-40090	RIVET, BLIND	2	
10	95024-06010	BOLT, FLANGE	2	
11	3GM-22141-01	SHAFT, PIVOT	1	
12	95607-18200	NUT, SELF-LOCKING	1	
13	4KG-22151-00	SEAL, GUARD	1	
14	95027-06025	BOLT, FLANGE	1	
15	90387-06022	COLLAR	1	
16	90201-060A3	WASHER, PLATE	1	

4PU351-5220

**D3**

FIG. 23 REAR SUSPENSION



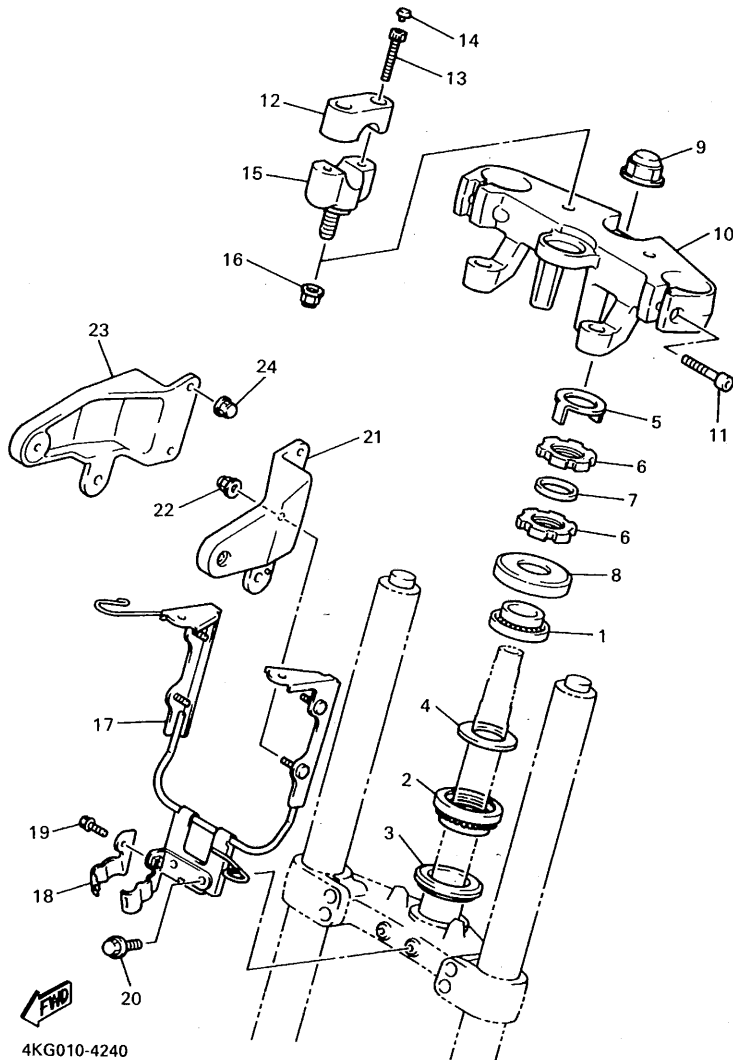
REF. NO.	PART NO.	DESCRIPTION	Q'TY	REMARKS
1	4PU-22210-00	SHOCK ABSORBER ASSY, REAR	2	
2	4KG-22216-00	•BUSH, REAR SHOCK ABSORBER	1	
3	1UF-22216-00	•BUSH, REAR SHOCK ABSORBER	1	
4	95024-10045	BOLT, FLANGE	2	
5	95617-10200	NUT, SELF-LOCKING	2	
6	95024-08012	BOLT, FLANGE	2	
7	1UJ-22243-00	WASHER 1	2	
8	5M0-22253-00	COLLAR, DISTANCE	2	



4PU351-5230

**D4**

FIG. 24 STEERING

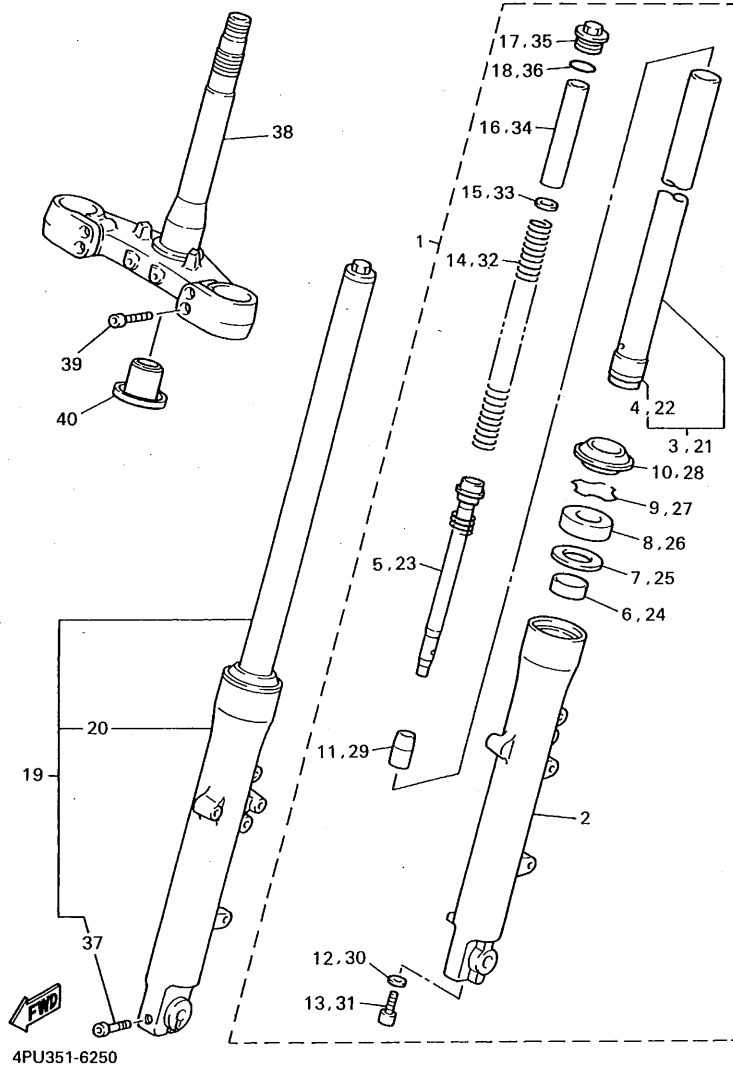


4KG010-4240

REF. NO.	PART NO.	DESCRIPTION	Q'TY	REMARKS
1	93399-99931	BEARING	1	
2	93399-99932	BEARING	1	
3	3FV-23462-00	SEAL, STEERING	1	
4	90202-24190	WASHER, PLATE	1	
5	26H-23418-01	WASHER, SPECIAL	1	
6	90179-25033	NUT	2	
7	90202-26142	WASHER, PLATE	1	
8	3HE-23416-00	COVER, BALL RACE 2	1	
9	90176-22050	NUT, CROWN	1	
10	4KG-23435-00	CROWN, HANDLE	1	
11	91314-08030	BOLT	2	
12	4H7-23441-00-38	HOLDER, HANDLE UPPER	2	CLEAR (WITH BUFF)
13	91314-08030	BOLT	4	
14	90338-08163	PLUG	4	
15	5H0-23442-01-38	HOLDER, HANDLE LOWER	2	CLEAR (WITH BUFF)
16	95617-10200	NUT, SELF-LOCKING	2	
17	4KG-23174-00	STAY, HEADLIGHT	1	
18	3GM-23378-00	BRACKET	1	
19	95027-06012	BOLT, FLANGE	1	
20	95027-06020	BOLT, FLANGE	2	
21	4KG-23121-00	COVER, UPPER 1	1	
22	90176-06055	NUT, CROWN	2	
23	4KG-23131-00	COVER, UPPER 2	1	
24	90176-06055	NUT, CROWN	2	



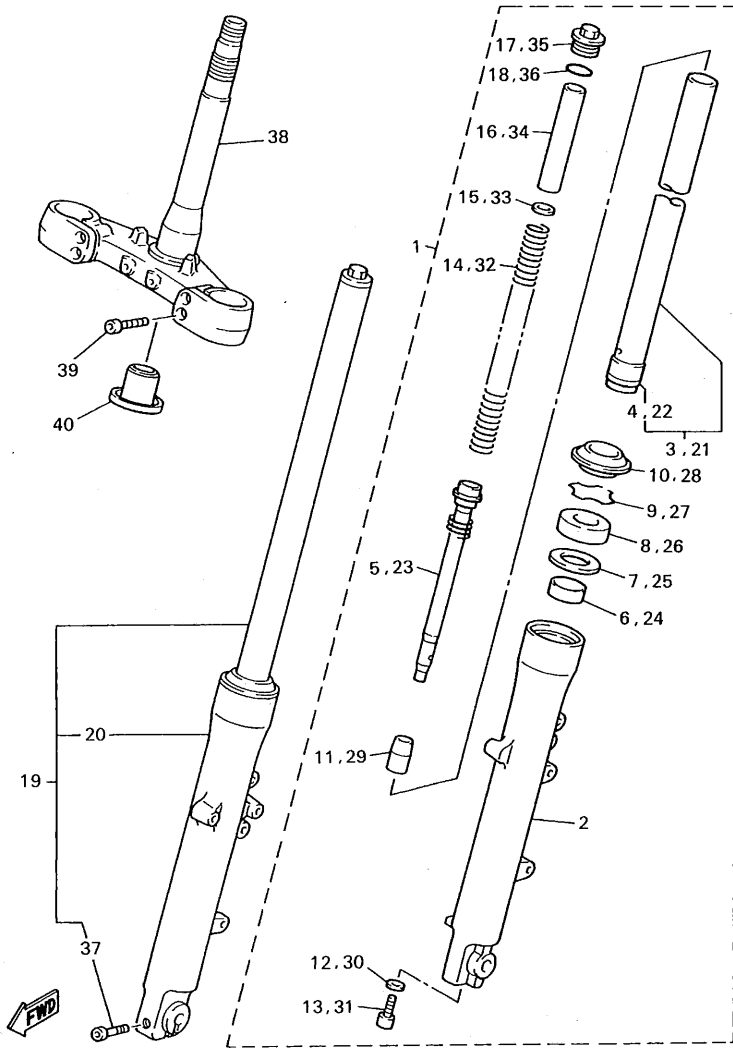
FIG. 25 FRONT FORK



REF. NO.	PART NO.	DESCRIPTION	Q'TY	REMARKS
1	4PU-23102-00	FRONT FORK ASSY (L.H)	1	
2	4KG-23126-00	.TUBE, OUTER (LEFT)	1	
3	4PU-23110-00	.INNER TUBE COMP.1	1	
4	3XJ-23171-L0	..PISTON, FRONT FORK	1	
5	4PU-23170-00	.CYLINDER COMP., FRONT FORK	1	
6	3XJ-23125-L0	.METAL, SLIDE 1	1	
7	4V4-23146-L0	.WASHER, OIL SEAL	1	
8	4KG-23145-00	.OIL SEAL	1	
9	4V4-23153-L0	.RING, SNAP	1	
10	4KG-23144-00	.SEAL, DUST	1	
11	3GM-23173-00	.SPINDLE, TAPER	1	
12	509-23158-L0	.GASKET	1	
13	278-23181-50	.BOLT, HEXAGON SOCKET HEAD	1	
14	4PU-23141-00	.SPRING, FRONT FORK	1	
15	3LR-23149-00	.WASHER, SPRING UPPER	1	
16	4KG-23118-00	.SPACER	1	
17	3TJ-23111-00	.BOLT, CAP	1	
18	4V4-23188-L0	.O-RING	1	
19	4PU-23103-00	FRONT FORK ASSY (R.H)	1	
20	4KG-23136-00	.TUBE, OUTER (RIGHT)	1	
21	4PU-23110-00	.INNER TUBE COMP.1	1	
22	3XJ-23171-L0	..PISTON, FRONT FORK	1	
23	4PU-23170-00	.CYLINDER COMP., FRONT FORK	1	
24	3XJ-23125-L0	.METAL, SLIDE 1	1	
25	4V4-23146-L0	.WASHER, OIL SEAL	1	
26	4KG-23145-00	.OIL SEAL	1	
27	4V4-23153-L0	.RING, SNAP	1	
28	4KG-23144-00	.SEAL, DUST	1	

FIG. 25 FRONT FORK

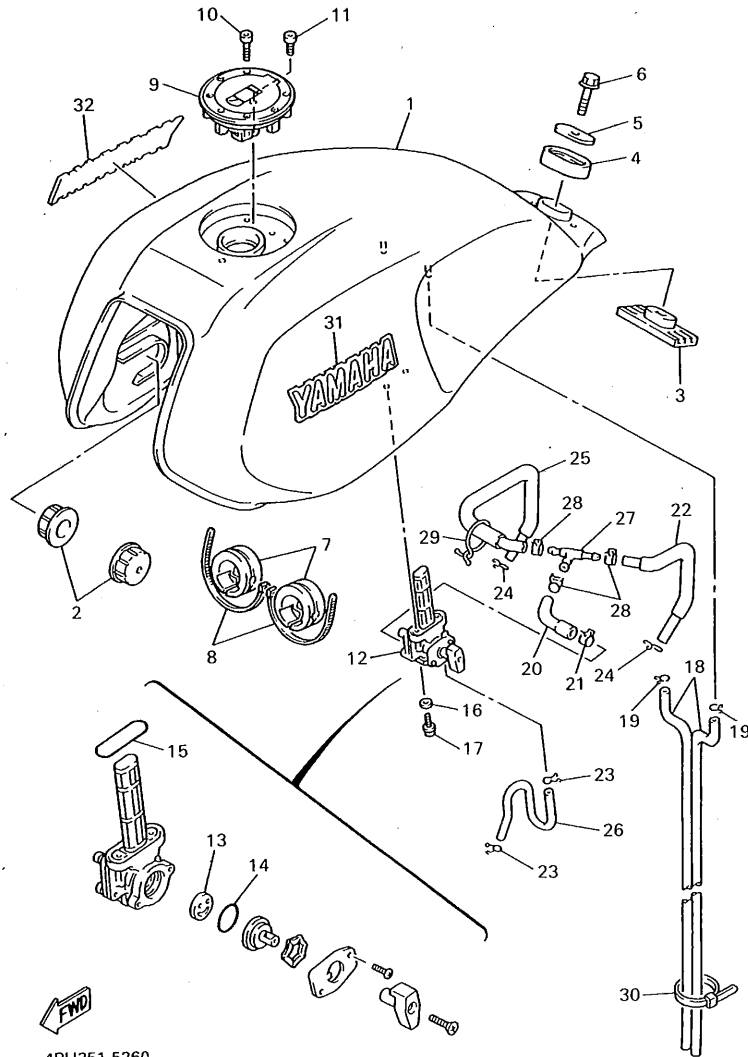
REF. NO.	PART NO.	DESCRIPTION	Q'TY	REMARKS
29	3GM-23173-00	.SPINDLE, TAPER	1	
30	509-23158-L0	.GASKET	1	
31	278-23181-50	.BOLT, HEXAGON SOCKET HEAD	1	
32	4PU-23141-00	.SPRING, FRONT FORK	1	
33	3LR-23149-00	.WASHER, SPRING UPPER	1	
34	4KG-23118-00	.SPACER	1	
35	3TJ-23111-00	.BOLT, CAP	1	
36	4V4-23188-L0	.O-RING	1	
37	91314-08045	.BOLT	1	
38	4PU-23340-00	UNDER BRACKET COMP.	1	
39	91317-08025	BOLT	4	
40	4KM-23123-01	COVER, LOWER 1	1	EXCEPT FOR OCEANIA



4PU351-6250

**D7**

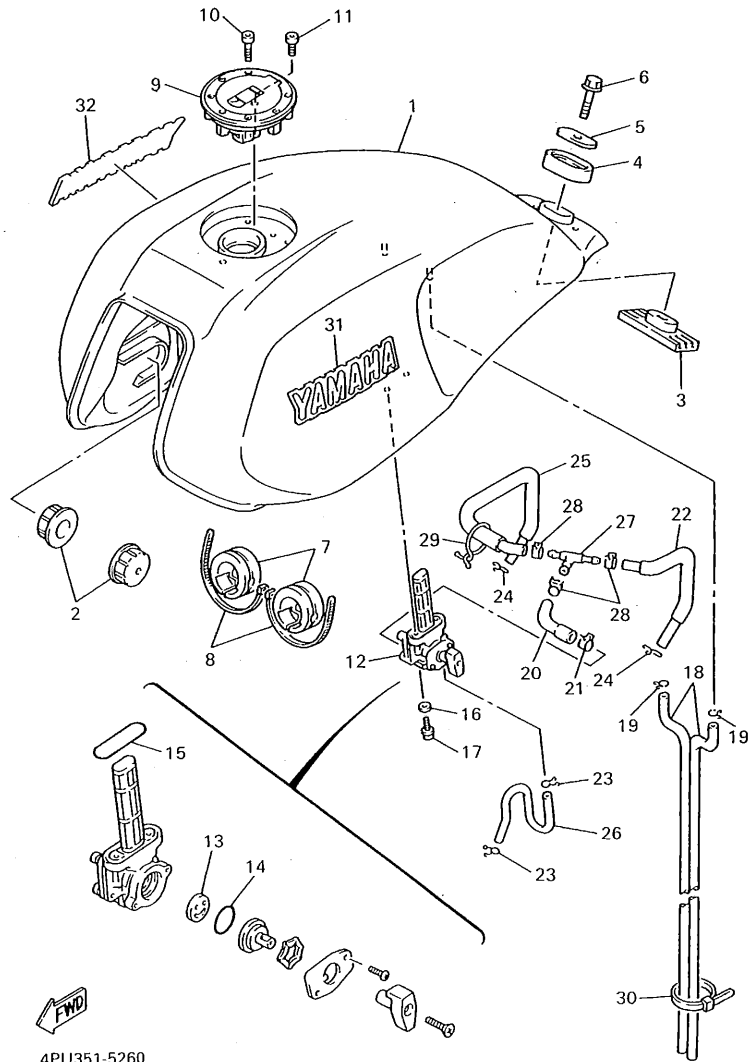
FIG. 26 FUEL TANK



4PU351-5260

REF. NO.	PART NO.	DESCRIPTION	Q'TY	REMARKS
1	4KG-24110-G0-P0	FUEL TANK COMP.	1	UR DEEP RED COCKTAIL 2 UR BLACK 2
	4KG-24110-G0-4B	FUEL TANK COMP.	1	
2	4H7-24181-00	DAMPER, LOCATING 1	2	
3	2GH-24184-00	DAMPER, LOCATING 4	1	
4	3Y6-24183-00	DAMPER, LOCATING 3	1	
5	12R-24186-00	WASHER, SPECIAL	1	
6	97007-08030	BOLT	1	
7	4HM-24183-00	DAMPER, LOCATING 3	2	
8	90464-14117	CLAMP	2	
9	4HN-24602-00	CAP ASSY	1	
10	90110-05112	BOLT, HEXAGON SOCKET HEAD	3	
11	91317-05010	BOLT	1	
12	4KG-24500-00	FUEL COCK ASSY 1	1	
13	3XV-24523-00	VALVE	1	
14	3XV-24534-00	SEAL, COCK	1	
15	4X8-24512-00	O-RING	1	
16	90202-05187	WASHER, PLATE	2	
17	90149-06008	SCREW	2	
18	90445-104H3	HOSE	2	
19	90467-09006	CLIP	2	
20	4KG-24311-00	PIPE, FUEL 1	1	
21	90467-14057	CLIP	1	
22	4KG-24312-00	PIPE 2	1	
23	90467-08021	CLIP	2	
24	90467-12052	CLIP	2	
25	4KG-24313-00	PIPE 3	1	
26	4KG-24314-00	PIPE 4	1	
27	90413-11025	WAY 3	1	

FIG. 26 FUEL TANK

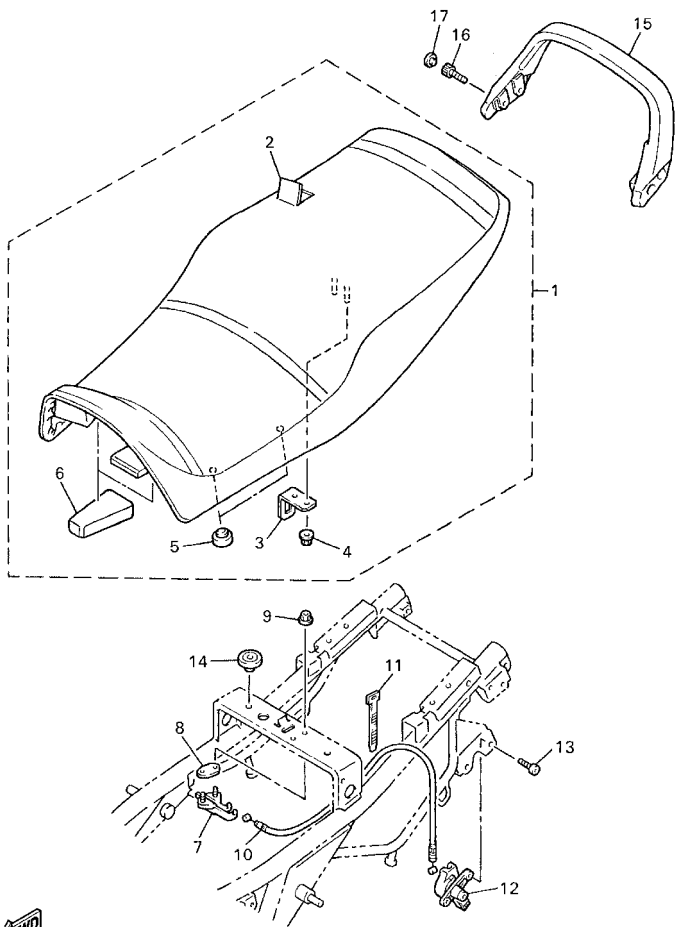


4PU351-5260

REF. NO.	PART NO.	DESCRIPTION	Q'TY	REMARKS
28	90467-13064	CLIP	3	
29	90464-30040	CLAMP	1	
30	90464-13073	CLAMP	1	
31	4KG-24161-00	EMBLEM 1	1	
32	4KG-24162-00	EMBLEM 2	1	

**D9**

FIG. 27 SEAT

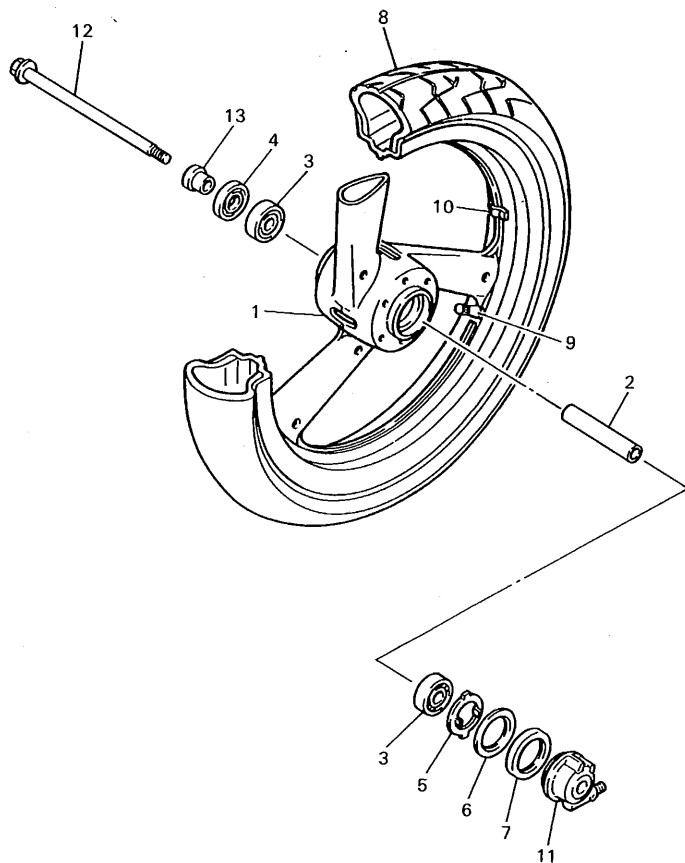


REF. NO.	PART NO.	DESCRIPTION	Q'TY	REMARKS
1	4PU-24730-00	DOUBLE SEAT ASSY	1	UR FOR OCEANIA
	4PU-24730-10	DOUBLE SEAT ASSY	1	UR
2	4PU-2470F-00	.COVER, SEAT	1	UR FOR OCEANIA
	4PU-24731-10	.COVER, SEAT	1	UR
3	4HM-24728-00	.BRACKET, SEAT	1	
4	95701-06500	.NUT, FLANGE	2	
5	22W-24741-00	.PAD, SEAT	4	
6	4KG-24737-00	.DAMPER, SEAT	2	
7	4BP-24780-00	SEAT LOCK ASSY	1	
8	4BP-24792-00	PLATE	1	
9	95707-06500	NUT, FLANGE	2	
10	4KG-2478E-00	CABLE, SEAT LOCK	1	
11	12R-82591-00	BAND	1	
12	3YX-21308-00	HELMET HANGER ASSY	1	
13	90149-06308	SCREW	2	
14	22W-24741-00	PAD, SEAT	2	
15	4KG-24773-00-P0	HANDLE, SEAT	1	UR DEEP RED
	4KG-24773-00-4B	HANDLE, SEAT	1	COCKTAIL 2 UR BLACK 2
16	91317-08025	BOLT	4	
17	90338-08163	PLUG	4	



4PU351-5271

FIG. 28 FRONT WHEEL



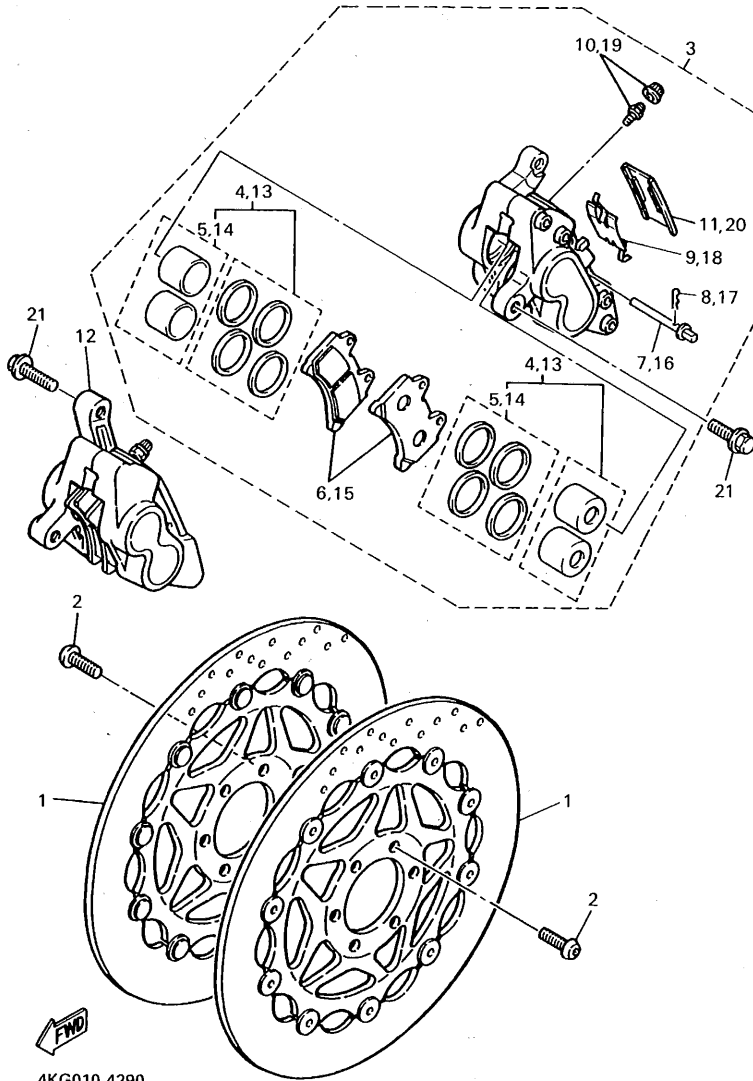
REF. NO.	PART NO.	DESCRIPTION	Q'TY	REMARKS
1	4KG-25168-00-7B	CAST WHEEL, FRONT	1	BLUISH BLACK 2
2	90560-17356	SPACER	1	
3	93306-20314	BEARING (B6203)	2	
4	93102-25017	OIL SEAL	1	
5	341-25149-00	CLUTCH, METER	1	
6	341-25846-00	RETAINER, CLUTCH	1	
7	93105-45017	OIL SEAL	1	
8	94113-1704W	TIRE(130/70ZR17 D202F T/L)	1	UR DUNLOP
	94113-1705M	TIRE(130/70ZR17 BT-54F)	1	UR BRIDGESTONE
9	93900-00030	VALVE, RIM	1	
10	29L-25398-00	BALANCER, WHEEL (10G)	1	UR
	29L-25398-10	BALANCER, WHEEL (20G)	1	UR
	29L-25398-20	BALANCER, WHEEL (30G)	1	UR
11	4KG-25190-01	GEAR UNIT ASSY	1	
12	5Y1-25381-01	AXLE, WHEEL	1	
13	90387-17530	COLLAR	1	



4KG010-4280

D11

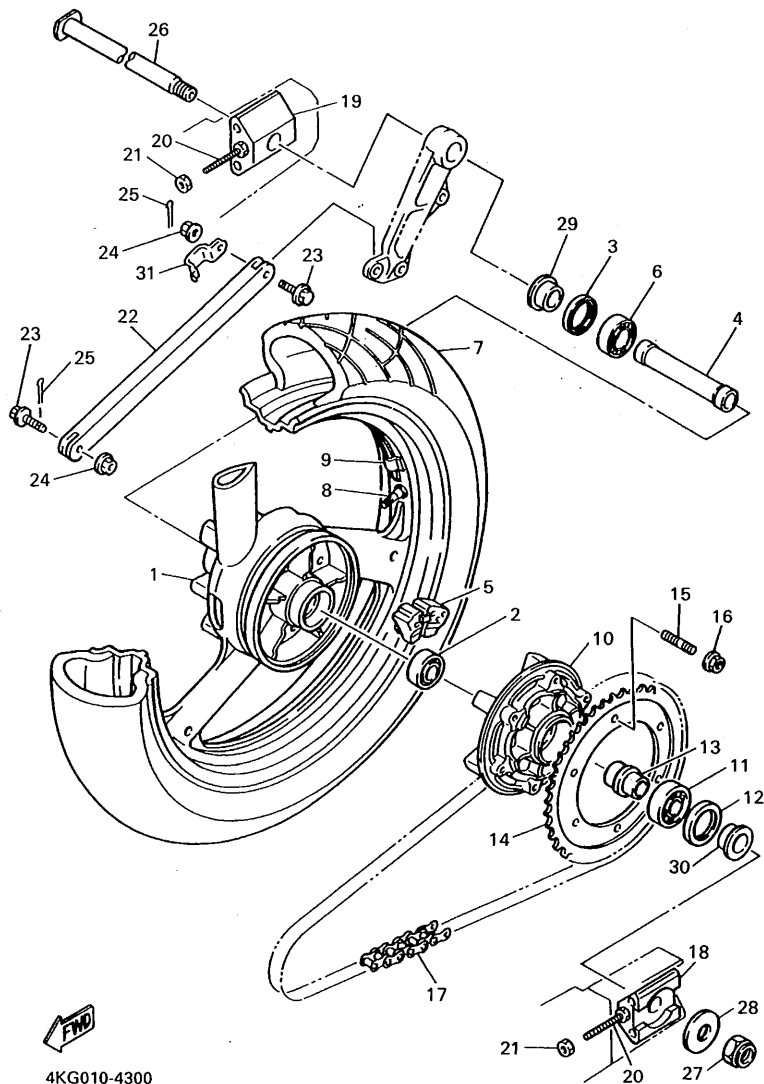
FIG. 29 FRONT BRAKE CALIPER



4KG010-4290

REF. NO.	PART NO.	DESCRIPTION	Q'TY	REMARKS
1	4KG-2581T-00	DISC BRAKE ASSY	2	
2	90109-08718	BOLT	12	
3	4KG-2580T-01	CALIPER ASSY (LEFT)	1	
4	1NL-W0057-00	PISTON ASSY, CALIPER	2	
5	1NL-W0047-00	CALIPER SEAL KIT	1	
6	4KG-W0045-00	BRAKE PAD KIT	1	
7	3HE-25924-00	PIN, PAD	2	
8	3GM-25925-00	CLIP	2	
9	2GH-25919-00	SUPPORT, PAD	1	
10	1J3-W0048-00	BLEED SCREW KIT	1	
11	1KT-25836-00	COVER, DUST	1	
12	4KG-2580U-01	CALIPER ASSY (RIGHT)	1	
13	1NL-W0057-00	PISTON ASSY, CALIPER	2	
14	1NL-W0047-00	CALIPER SEAL KIT	1	
15	4KG-W0045-00	BRAKE PAD KIT	1	
16	3HE-25924-00	PIN, PAD	2	
17	3GM-25925-00	CLIP	2	
18	2GH-25919-00	SUPPORT, PAD	1	
19	1J3-W0048-00	BLEED SCREW KIT	1	
20	1KT-25836-00	COVER, DUST	1	
21	90105-10638	BOLT, WASHER BASED	4	

FIG. 30 REAR WHEEL

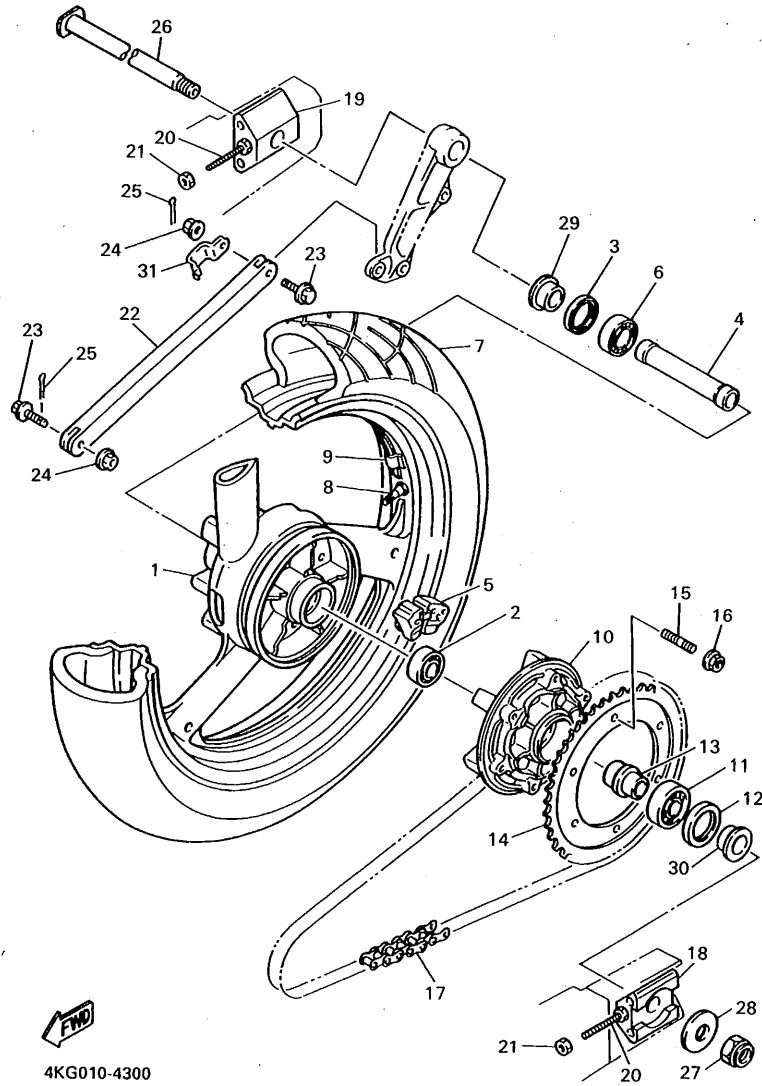


4KG010-4300

REF. NO.	PART NO.	DESCRIPTION	Q'TY	REMARKS
1	3GM-25338-01-7B	CAST WHEEL, REAR	1	BLUISH BLACK 2
2	93306-30416	BEARING (B6304RS)	1	
3	93106-30029	OIL SEAL	1	
4	90560-20357	SPACER	1	
5	4KG-25364-00	DAMPER	5	
6	93306-30437	BEARING	1	
7	94117-1704X	TIRE (170/60ZR17 D202L T/L)	1	UR DUNLOP
	94117-1705N	TIRE (170/60ZR17 BT-54R)	1	UR BRIDGESTONE
8	93900-00030	VALVE, RIM	1	
9	29L-25398-00	BALANCER, WHEEL (10G)	1	UR
	29L-25398-10	BALANCER, WHEEL (20G)	1	UR
	29L-25398-20	BALANCER, WHEEL (30G)	1	UR
10	36Y-25366-01	CLUTCH, HUB	1	
11	93306-30562	BEARING	1	
12	93106-35030	OIL SEAL	1	
13	36Y-25377-00	COLLAR, WHEEL	1	
14	4KG-25438-20	SPROCKET, DRIVEN (38T)	1	
15	90116-10485	BOLT, STUD	6	
16	95617-10200	NUT, SELF-LOCKING	6	
17	94581-57110	CHAIN (DID532ZLVKA1-110L)	1	DAIDO
18	3GM-25388-00	PULLER, CHAIN 1	1	
19	3GM-25389-00	PULLER, CHAIN 2	1	
20	90101-08766	BOLT	2	
21	95307-08600	NUT	2	
22	4FM-25371-10	BAR, TENSION	1	
23	90105-08321	BOLT, WASHER BASED	2	
24	95707-08500	NUT, FLANGE	2	
25	91490-20025	PIN, COTTER	2	

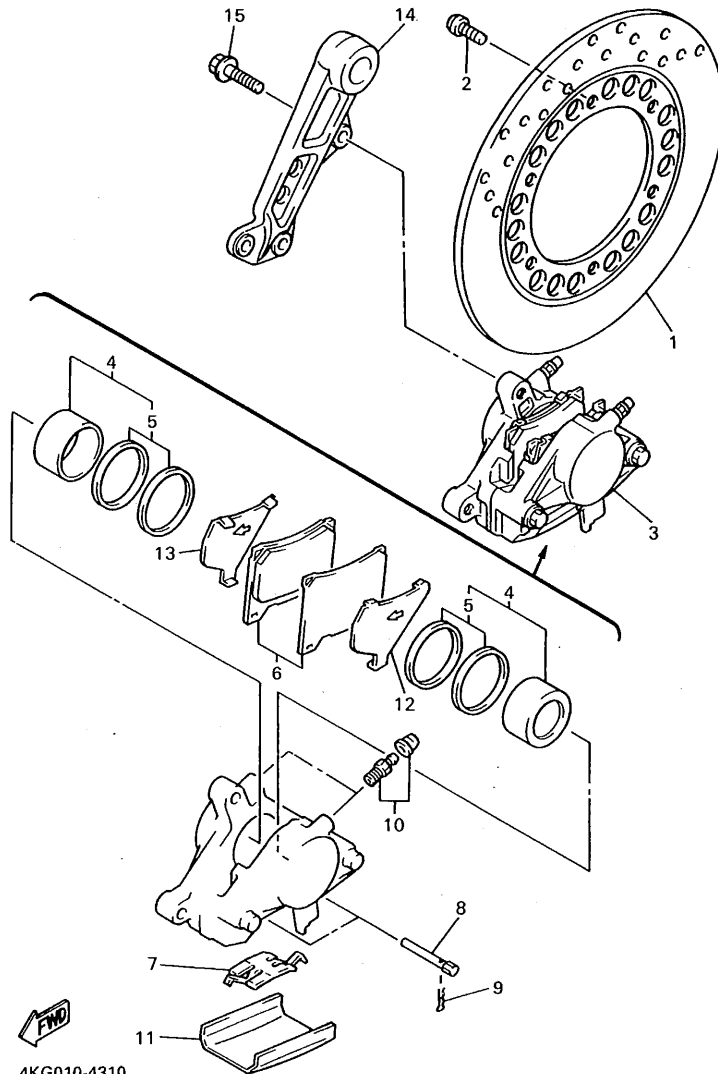


FIG. 30 REAR WHEEL



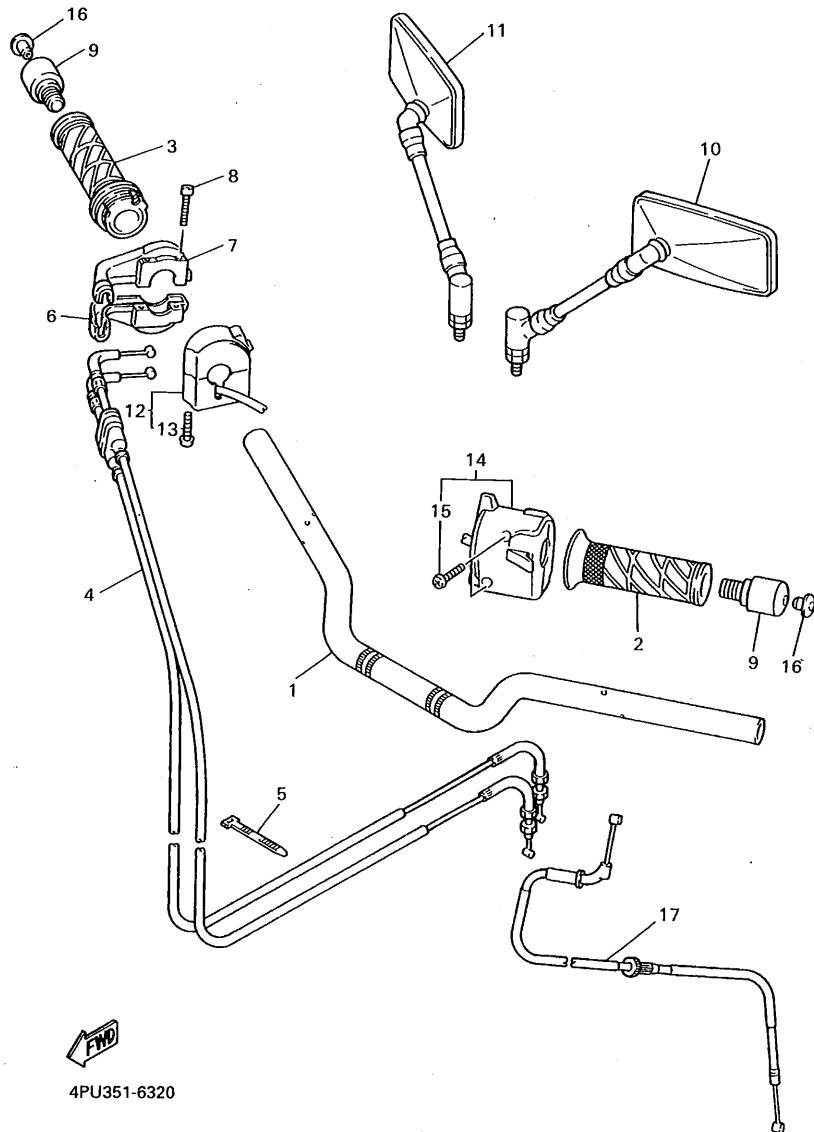
REF. NO.	PART NO.	DESCRIPTION	Q'TY	REMARKS
26	3GM-25381-A0	AXLE, WHEEL	1	
27	95604-18200	NUT, SELF-LOCKING	1	
28	90201-18264	WASHER, PLATE	1	
29	90387-202X9	COLLAR	1	
30	90387-203X0	COLLAR	1	
31	4FM-25887-01	HOLDER, BRAKE HOSE	1	

FIG. 31 REAR BRAKE CALIPER



REF. NO.	PART NO.	DESCRIPTION	Q'TY	REMARKS
1	3GM-2582W-A0	DISC, REAR BRAKE 2	1	
2	90109-08718	BOLT	6	
3	4KG-2580W-00	CALIPER ASSY, REAR 2	1	
4	31A-W0057-00	PISTON ASSY, CALIPER	1	
5	31A-W0047-00	CALIPER SEAL KIT	1	
6	1FK-W0046-02	BRAKE PAD KIT 2	1	
7	29L-25919-A0	SUPPORT, PAD	1	
8	3HE-25924-00	PIN, PAD	2	
9	3GM-25925-00	CLIP	2	
10	1J3-W0048-00	BLEED SCREW KIT	2	
11	51J-25836-00	COVER, DUST	1	
12	1FK-25827-00	SHIM, CALIPER	1	
13	1FK-25828-00	SHIM, CALIPER	1	
14	4KG-25819-00	BRACKET, CALIPER	1	
15	90105-10638	BOLT, WASHER BASED	2	

FIG. 32 STEERING HANDLE • CABLE

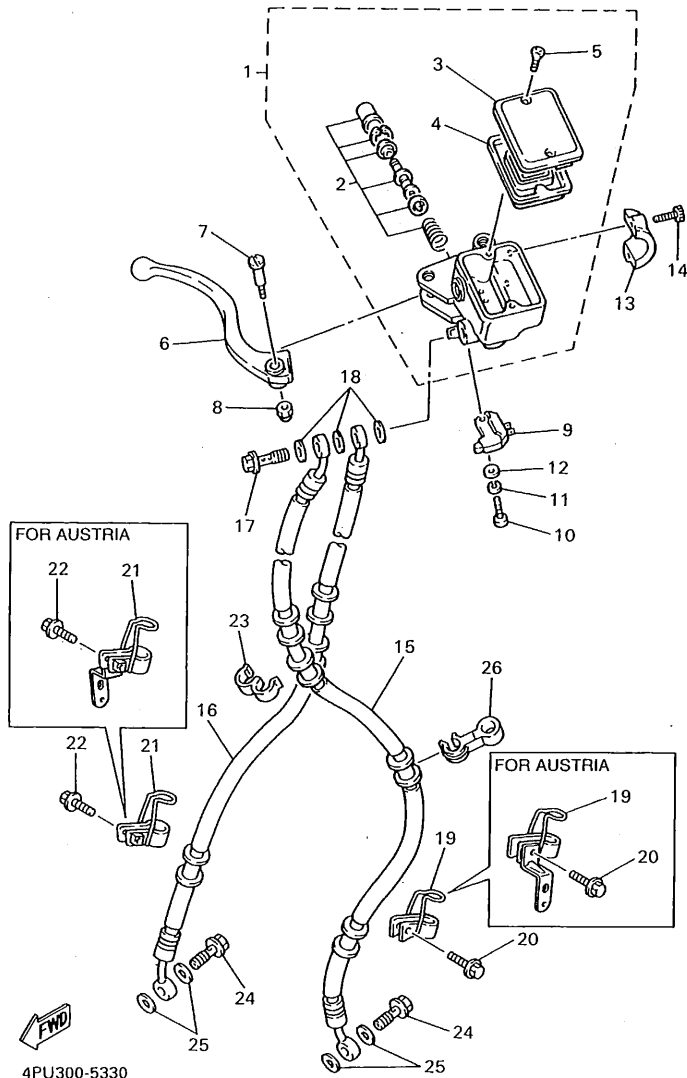


REF. NO.	PART NO.	DESCRIPTION	Q'TY	REMARKS
1	4KG-26111-10	HANDLEBAR	1	UR FOR OCEANIA
	4KG-26111-30	HANDLEBAR	1	UR
2	4FM-26241-00	GRIP (LEFT)	1	
3	4FM-26240-00	GRIP ASSY	1	
4	4KG-26302-00	THROTTLE CABLE ASSY	1	
5	12R-82591-00	BAND	1	
6	4KG-26281-00	CAP, GRIP UPPER	1	
7	3XW-26282-01	CAP, GRIP LOWER	1	
8	91317-05035	BOLT	2	
9	3HX-26246-00	END, GRIP	2	
10	4H7-26290-A1	BACK MIRROR ASSY (LEFT)	1	
11	4H7-26290-E1	BACK MIRROR ASSY (RIGHT)	1	
12	4HM-83975-11	SWITCH, HANDLE 2	1	UR FOR OCEANIA
	4PU-83963-00	SWITCH, HANDLE 3	1	UR
13	90157-05027	•SCREW, PAN HEAD	2	UR FOR OCEANIA
	98507-05045	•SCREW, PAN HEAD	2	UR
14	4UW-83972-00	SWITCH, HANDLE 4	1	
15	98507-05025	•SCREW, PAN HEAD	2	
16	4X7-23469-10	CAP, BOLT	2	
17	4KG-26330-00	STARTER CABLE ASSY	1	



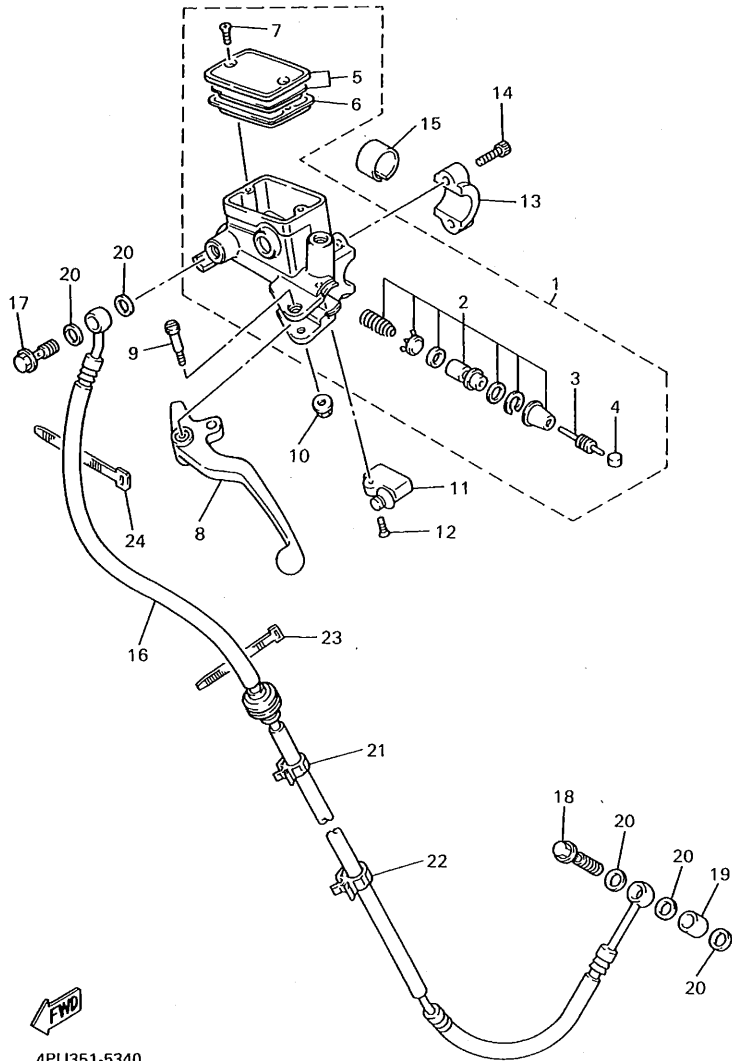
4PU351-6320

FIG. 33 FRONT MASTER CYLINDER



REF. NO.	PART NO.	DESCRIPTION	Q'TY	REMARKS
1	4KG-W2587-00	MASTER CYLINDER SUB ASSY	1	
2	4K0-W0041-50	.CYLINDER KIT, MASTER	1	
3	4HM-W2585-00	.RESERVOIR CAP SET	1	
4	4HM-25854-00	.DIAPHRAGM, RESERVOIR	1	
5	98707-04012	.SCREW, FLAT HEAD	2	
6	4PU-83922-00	LEVER 2	1	
7	3FV-2589F-00	BOLT, LEVER	1	
8	95617-06100	NUT, U	1	
9	3FV-83980-00	FRONT STOP SWITCH ASSY	1	
10	98517-04012	SCREW, PAN HEAD	1	
11	92990-04100	WASHER, SPRING	1	
12	92901-04600	WASHER, PLATE	1	
13	4HM-25867-00	BRACKET, MASTER CYLINDER	1	
14	91317-06020	BOLT	2	
15	4KG-25872-00	HOSE, BRAKE 1	1	
16	4KG-25873-00	HOSE, BRAKE 2	1	
17	90401-10160	BOLT, UNION	1	
18	90201-10118	WASHER, PLATE	3	
19	4KG-25887-00	HOLDER, BRAKE HOSE	1	UR
	4RB-25887-00	HOLDER, BRAKE HOSE	1	UR FOR AUSTRIA
20	95027-06025	BOLT, FLANGE	1	
21	4KG-25876-00	HOLDER, BRAKE HOSE 2	1	UR
	4RB-25876-00	HOLDER, BRAKE HOSE 2	1	UR FOR AUSTRIA
22	95027-06025	BOLT, FLANGE	1	
23	90464-13194	CLAMP	1	
24	90401-10159	BOLT, UNION	2	
25	90201-10118	WASHER, PLATE	4	
26	3MA-26279-00	GUIDE, CABLE	1	

FIG. 34 FRONT MASTER CYLINDER 2

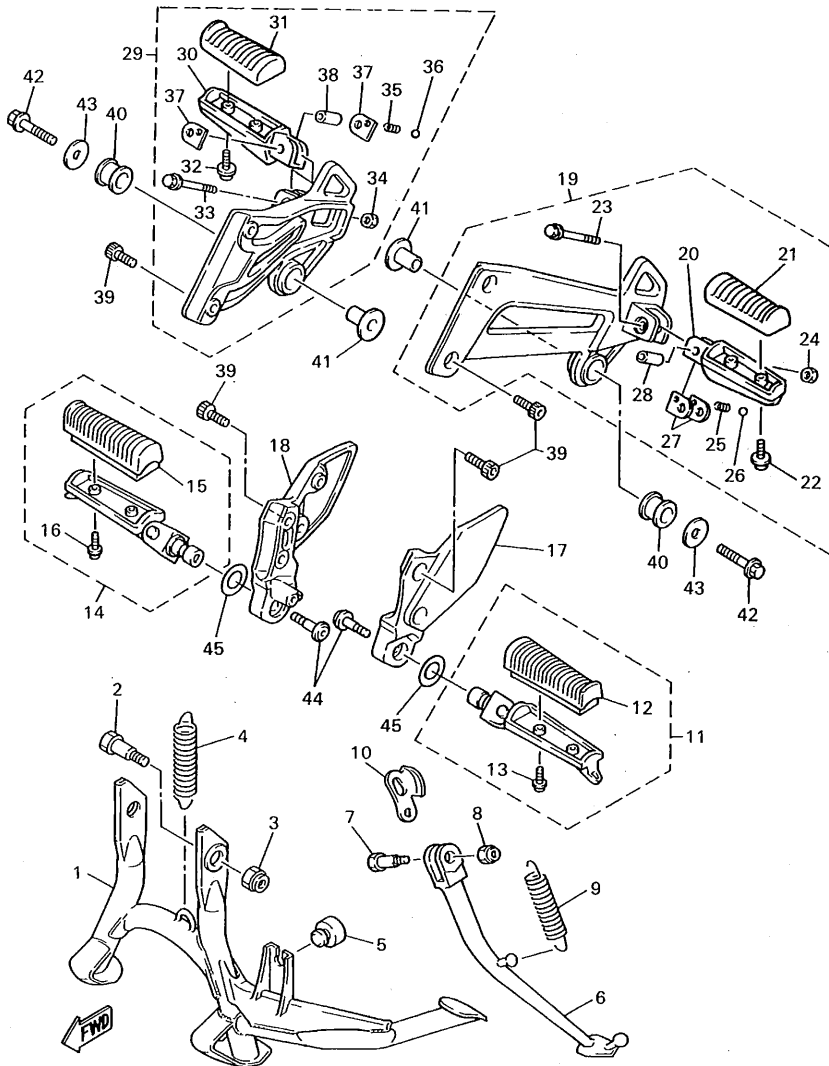


REF. NO.	PART NO.	DESCRIPTION	Q'TY	REMARKS
1	4KG-W2645-00	MASTER CYLINDER SUB ASSY	1	
2	3GM-W0099-00	•CYLINDER KIT, MASTER (CLUTCH)	1	
3	3GM-26464-00	•ROD, PUSH	1	
4	3GM-26455-00	•BUSH	1	
5	4HM-W2585-00	•RESERVOIR CAP SET	1	
6	4HM-25854-00	•DIAPHRAGM, RESERVOIR	1	
7	98707-04012	•SCREW, FLAT HEAD	2	
8	4PU-83912-00	LEVER 1	1	
9	3FV-2589F-00	BOLT, LEVER	1	
10	95706-06500	NUT, FLANGE	1	
11	3GM-83980-00	FRONT STOP SWITCH ASSY	1	
12	98706-04016	SCREW, FLAT HEAD	1	
13	4KG-25867-00	BRACKET, MASTER CYLINDER	1	
14	91317-06020	BOLT	2	
15	90387-22660	COLLAR	1	
16	4KG-26470-00	HOSE, CLUTCH	1	
17	90401-10159	BOLT, UNION	1	
18	90401-10160	BOLT, UNION	1	
19	90387-1005B	COLLAR	1	
20	90201-10118	WASHER, PLATE	5	
21	90464-10190	CLAMP	1	
22	90464-15192	CLAMP	1	
23	12R-82591-00	BAND	1	
24	437-83936-01	BAND, SWITCH CORD	2	



4PU351-5340

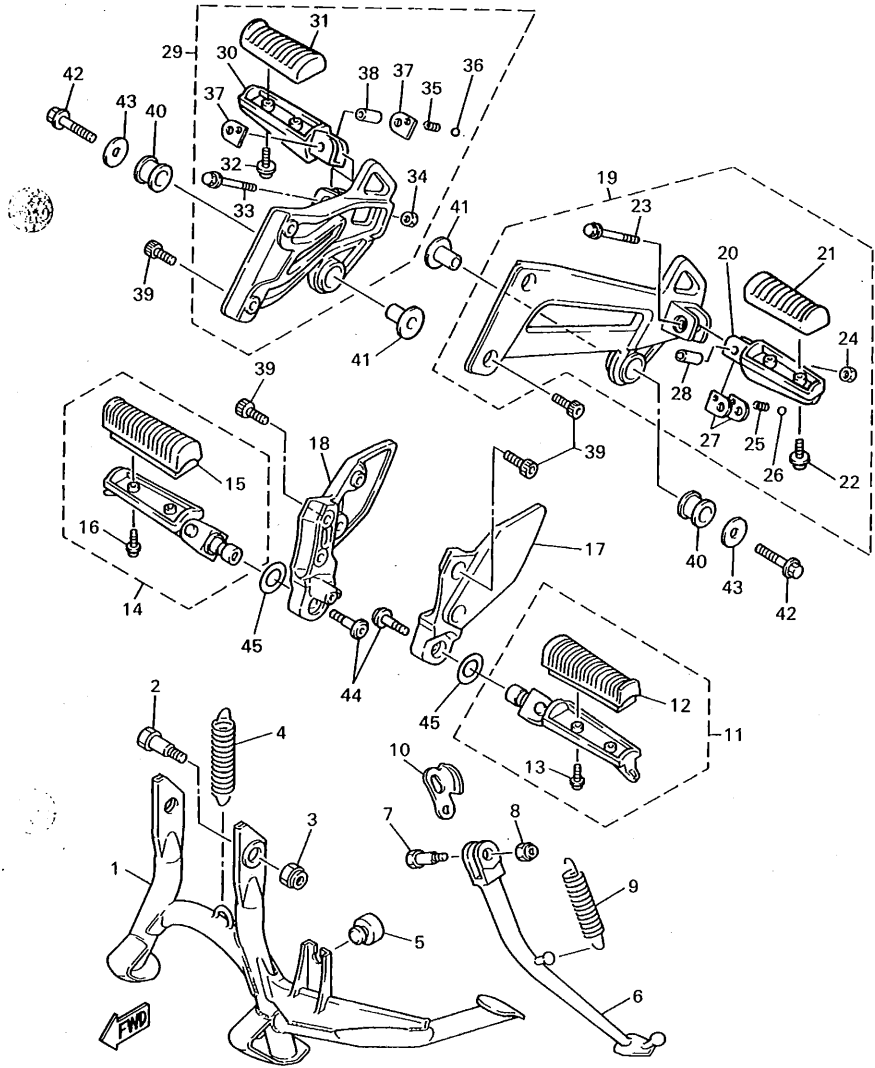
FIG. 35 STAND • FOOTREST



4PU351-6350

REF. NO.	PART NO.	DESCRIPTION	Q'TY	REMARKS
1	4KG-27111-01	STAND, MAIN	1	
2	90109-101E6	BOLT	2	
3	90185-10091	NUT, SELF-LOCKING	2	
4	90506-45278	SPRING, TENSION	1	
5	116-27114-00	STOPPER, MAIN STAND	1	
6	4KG-27311-01	STAND, SIDE	1	
7	90109-104E6	BOLT	1	
8	90185-10037	NUT, SELF-LOCKING	1	
9	90506-26467	SPRING, TENSION	1	
10	4FM-27315-00	LINK, SIDE STAND	1	
11	4KG-27410-01	FRONT FOOTREST ASSY (LEFT)	1	
12	4BP-27413-00	.COVER, FOOTREST	1	
13	90157-05079	.SCREW, PAN HEAD	2	
14	4KG-27420-01	FRONT FOOTREST ASSY (RIGHT)	1	
15	4BP-27413-00	.COVER, FOOTREST	1	
16	90157-05079	.SCREW, PAN HEAD	2	
17	4KG-27442-01	BRACKET 2	1	
18	4KG-27443-01	BRACKET 3	1	
19	4KG-27430-03	REAR FOOTREST ASSY 1	1	
20	4DN-27431-01	.FOOTREST, REAR 1	1	
21	4BP-27413-00	.COVER, FOOTREST	1	
22	90157-05079	.SCREW, PAN HEAD	2	
23	91317-06045	.BOLT	1	
24	95607-06200	.NUT, SELF-LOCKING	1	
25	90501-12743	.SPRING, COMPRESSION	1	
26	93501-04011	.BALL	1	
27	1HX-27437-00	.WASHER, SPECIAL	2	
28	90387-064H8	.COLLAR	1	

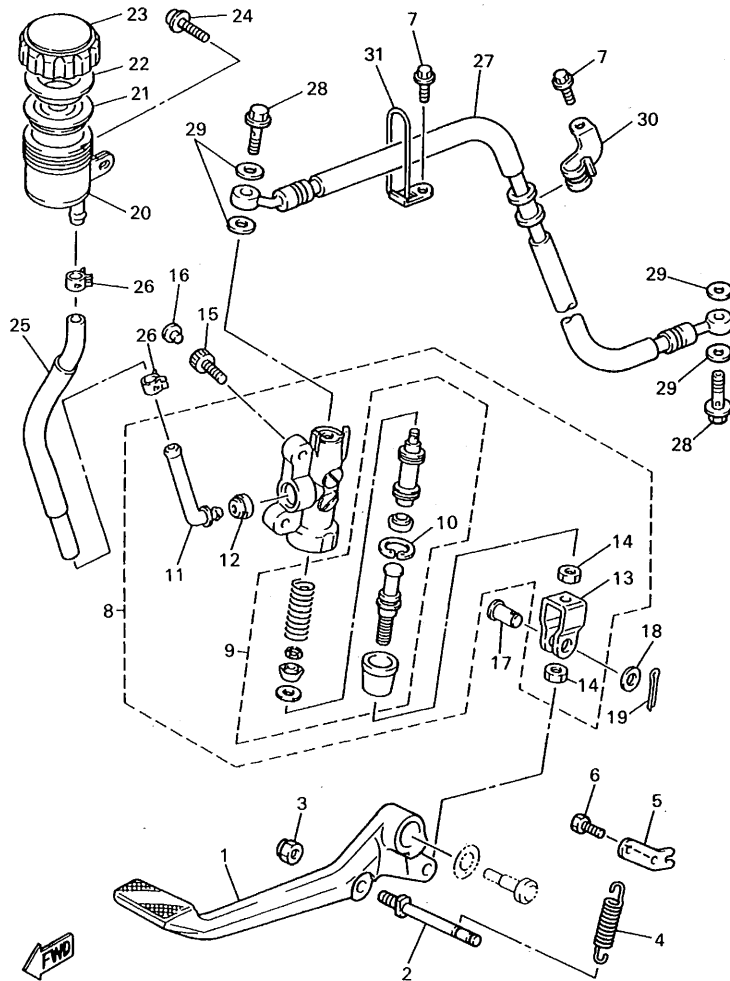
FIG. 35 STAND • FOOTREST



REF. NO.	PART NO.	DESCRIPTION	Q'TY	REMARKS
29	4KG-27440-03	REAR FOOTREST ASSY 2	1	
30	4DN-27441-01	•FOOTREST, REAR 2	1	
31	4BP-27413-00	•COVER, FOOTREST	1	
32	90157-05079	•SCREW, PAN HEAD	2	
33	91317-06045	•BOLT	1	
34	95607-06200	•NUT, SELF-LOCKING	1	
35	90501-12743	•SPRING, COMPRESSION	1	
36	93501-04011	•BALL	1	
37	1HX-27437-00	•WASHER, SPECIAL	2	
38	90387-064H8	•COLLAR	1	
39	90109-081G0	BOLT	8	
40	36Y-27424-00	DAMPER, FOOTREST 2	2	
41	90387-10636	COLLAR	2	
42	90109-100G0	BOLT	2	
43	90201-10669	WASHER, PLATE	2	
44	90109-103A9	BOLT	2	
45	90206-17084	WASHER, WAVE	2	

4PU351-6350

FIG. 36 REAR MASTER CYLINDER



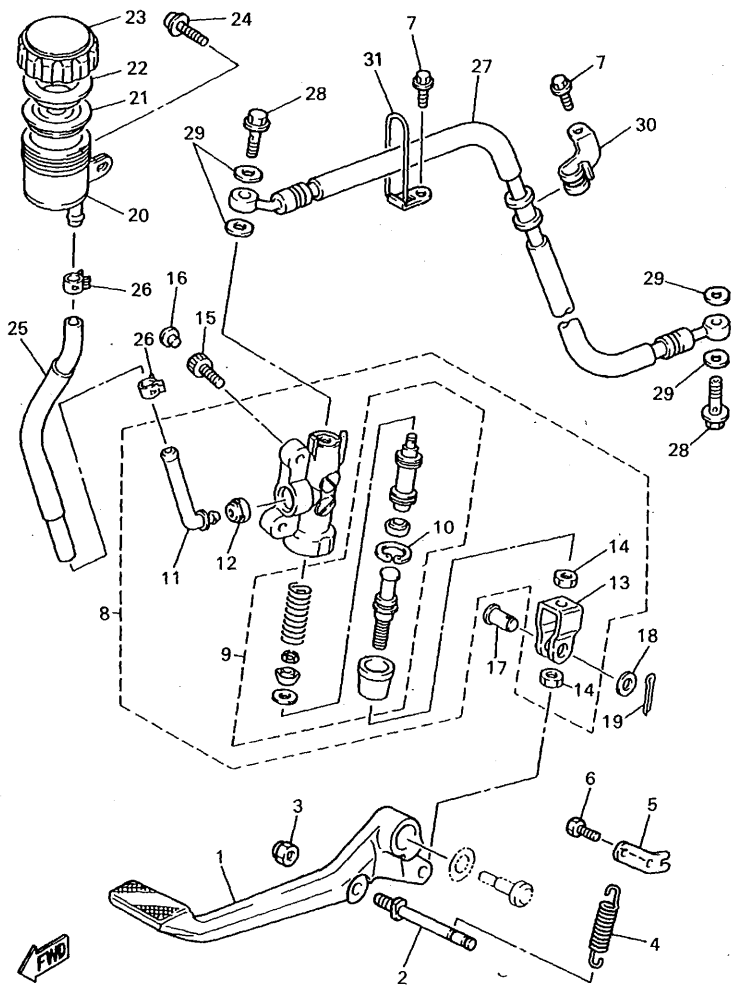
4KG010-5360

REF. NO.	PART NO.	DESCRIPTION	Q'TY	REMARKS
1	4KG-27211-00	PEDAL, BRAKE	1	
2	4KG-27813-00	PIN, PEDAL CRANK	1	
3	95607-08100	NUT, U	1	
4	90508-20737	SPRING, TORSION	1	
5	4KG-27432-00	BRACKET 1	1	
6	97007-06012	BOLT	1	
7	95027-06010	BOLT, FLANGE	2	
8	4BP-2583V-00	RR. MASTER CYLINDER ASSY.	1	
9	3TU-W0042-51	•CYLINDER KIT, MASTER	1	
10	3LN-2585G-00	•CIRCLIP	1	
11	4BP-2582A-00	•JOINT	1	
12	4BP-2585F-00	•BUSH	1	
13	4BP-27222-00	•JOINT	1	
14	95304-08700	•NUT	2	
15	91314-08020	BOLT	2	
16	90338-08163	PLUG	2	
17	90240-08124	PIN, CLEVIS	1	
18	90201-08083	WASHER, PLATE	1	
19	91490-20025	PIN, COTTER	1	
20	31A-25894-01	TANK, RESERVOIR	1	
21	360-25854-00	DIAPHRAGM, RESERVOIR	1	
22	2GU-25855-00	BUSH,DIAPHRAGM	1	
23	2KF-25852-50	CAP, RESERVOIR	1	
24	90159-06056	SCREW, WITH WASHER	1	
25	4KG-25895-00	HOSE, RESERVOIR	1	
26	90467-14057	CLIP	2	
27	4KG-2581K-00	HOSE, BRAKE 5	1	
28	90401-10159	BOLT, UNION	2	



FIG. 36 REAR MASTER CYLINDER

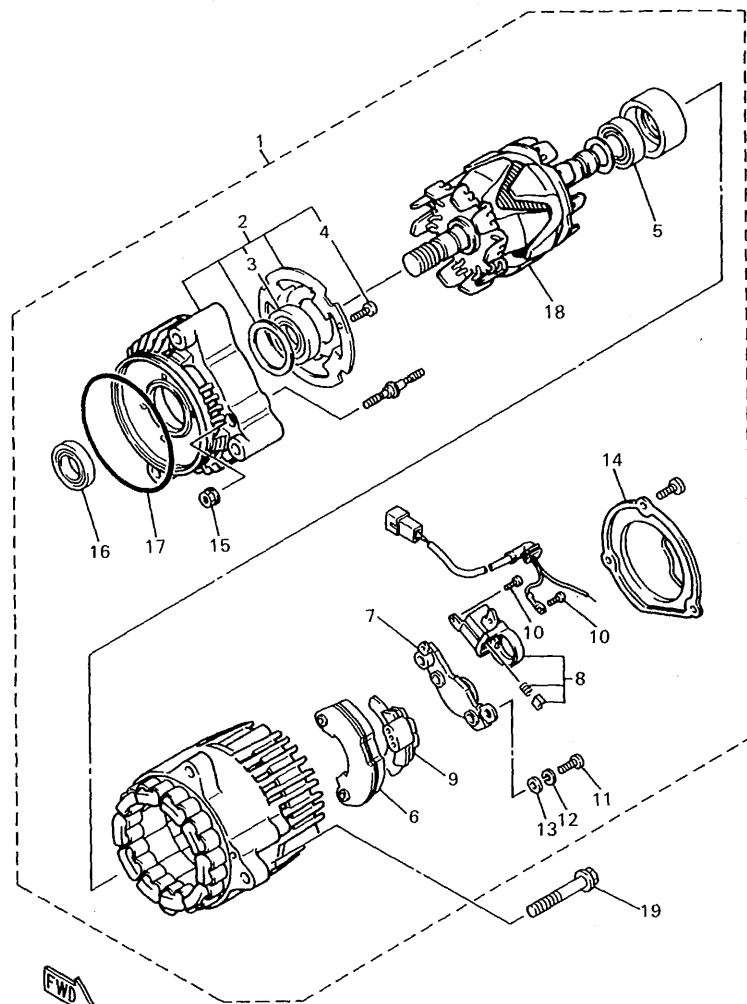
REF. NO.	PART NO.	DESCRIPTION	Q'TY	REMARKS
29	90201-10118	WASHER, PLATE	4	
30	4FM-25876-00	HOLDER, BRAKE HOSE 2	1	
31	4BH-25886-00	HOLDER, BRAKE HOSE	1	



4KG010-5360

**E8**

FIG. 37 GENERATOR

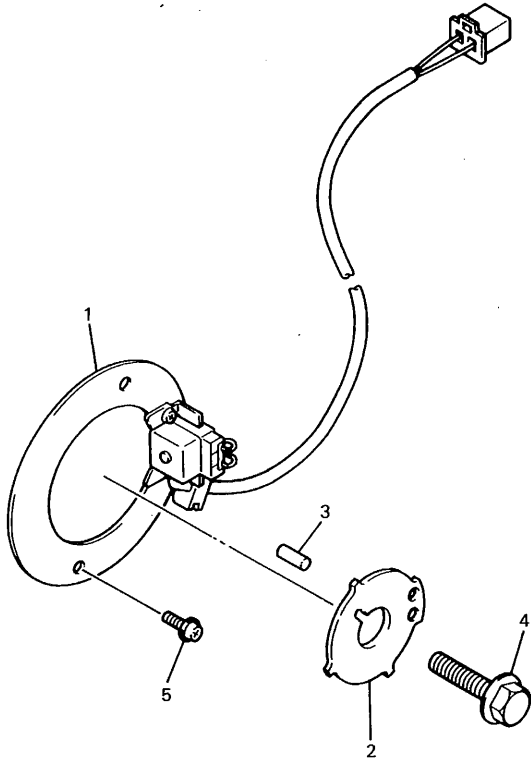


4BH332-3430

REF. NO.	PART NO.	DESCRIPTION	Q'TY	REMARKS
1	4KG-81600-00	A.C. GENERATOR ASSY	1	
2	4KG-81634-00	•STATOR ASSY	1	
3	4BH-81643-00	•BEARING	1	
4	4BH-81645-00	•SCREW	4	
5	4BH-81643-10	•BEARING	1	
6	4BH-81970-00	•RECTIFIER ASSY	1	
7	36Y-81910-50	•VOLTAGE REGULATOR ASSY	1	
8	3FV-81619-00	•BRUSH HOLDER ASSY	1	
9	4BH-81972-00	•COVER, RECTIFIER	1	
10	3FV-81645-00	•SCREW	2	
11	98507-05018	•SCREW, PAN HEAD	3	
12	92901-05100	•WASHER, SPRING	3	
13	92990-05600	•WASHER, PLATE	3	
14	4BH-81604-00	•COVER ASSY	1	
15	95707-05500	•NUT, FLANGE	2	
16	36Y-81638-50	•OIL SEAL	1	
17	2KT-81642-50	•O-RING	1	
18	4BH-81660-00	•ROTOR ASSY	1	
19	90105-080A5	BOLT, WASHER BASED	3	

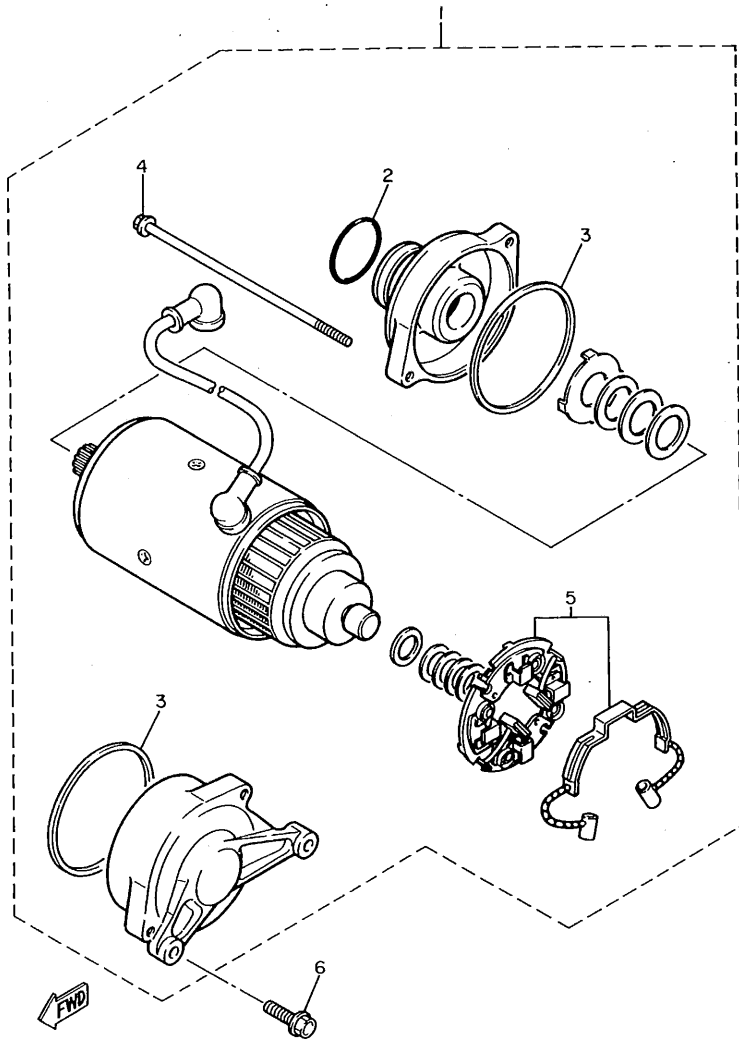
FIG. 38 PICK UP COIL • GOVERNOR

REF. NO.	PART NO.	DESCRIPTION	Q'TY	REMARKS
1	4KG-81671-00	BASE, PICKUP	1	
2	4KG-81673-00	ROTOR	1	
3	93604-08071	PIN, DOWEL	1	
4	90105-10445	BOLT, WASHER BASED	1	
5	90159-06107	SCREW, WITH WASHER	2	



4KG010-4380

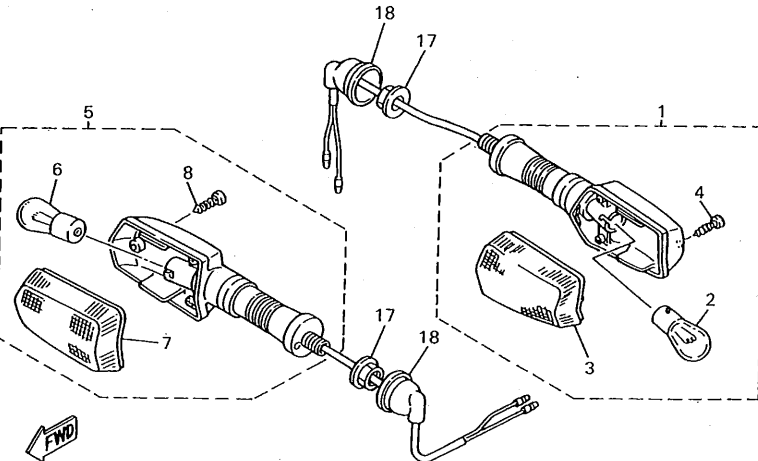
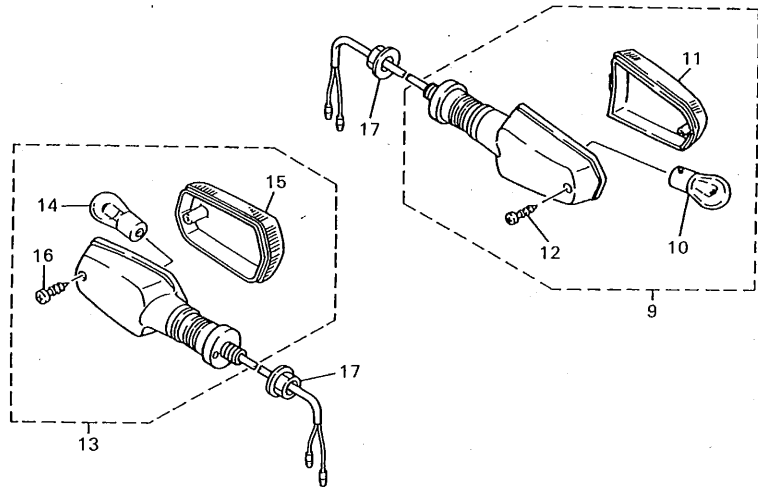
FIG. 39 STARTING MOTOR



3YA332-1410

REF. NO.	PART NO.	DESCRIPTION	Q'TY	REMARKS
1	4KG-81800-00	STARTING MOTOR ASSY	1	
2	26H-81847-00	•O-RING	1	
3	11H-81844-00	•GASKET	2	
4	3AJ-81826-00	•BOLT	2	
5	3AJ-81801-00	•BRUSH SET	1	
6	90105-060A0	BOLT, WASHER BASED	2	

FIG. 40 FLASHER LIGHT

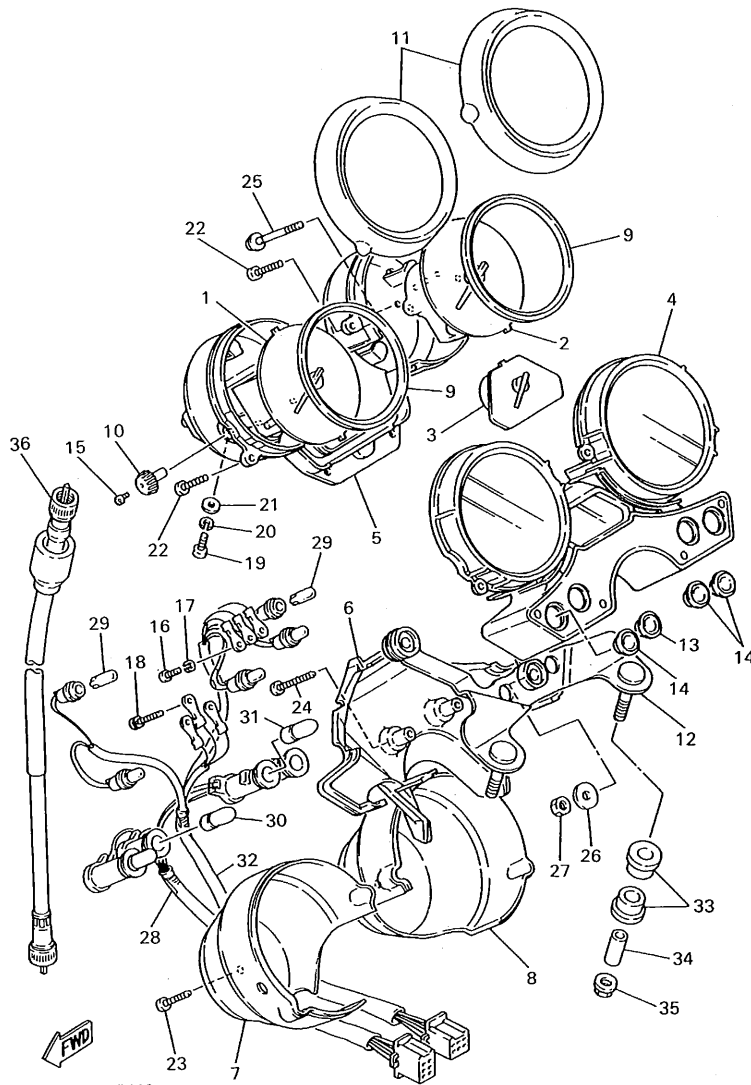


REF. NO.	PART NO.	DESCRIPTION	Q'TY	REMARKS
1	4PU-83310-00	FRONT FLASHER LIGHT ASSY 1	1	
2	306-83311-40	•BULB, FLASHER (12V-21W)	1	
3	51L-83332-01	•LENS, FLASHER	1	
4	97780-40120	•SCREW, TAPPING	1	
5	4PU-83320-00	FRONT FLASHER LIGHT ASSY 2	1	
6	306-83311-40	•BULB, FLASHER (12V-21W)	1	
7	51L-83342-01	•LENS, FLASHER 2	1	
8	97780-40120	•SCREW, TAPPING	1	
9	4PU-83330-00	REAR FLASHER LIGHT ASSY 1	1	
10	306-83311-40	•BULB, FLASHER (12V-21W)	1	
11	1VU-83332-00	•LENS, FLASHER	1	
12	97780-40120	•SCREW, TAPPING	1	
13	4PU-83340-00	FLASHER LIGHT ASSY 2	1	
14	306-83311-40	•BULB, FLASHER (12V-21W)	1	
15	1VU-83342-00	•LENS, FLASHER 2	1	
16	97780-40120	•SCREW, TAPPING	1	
17	95707-12500	NUT, FLANGE	4	
18	18G-83365-00	CAP	2	



4PU351-5400

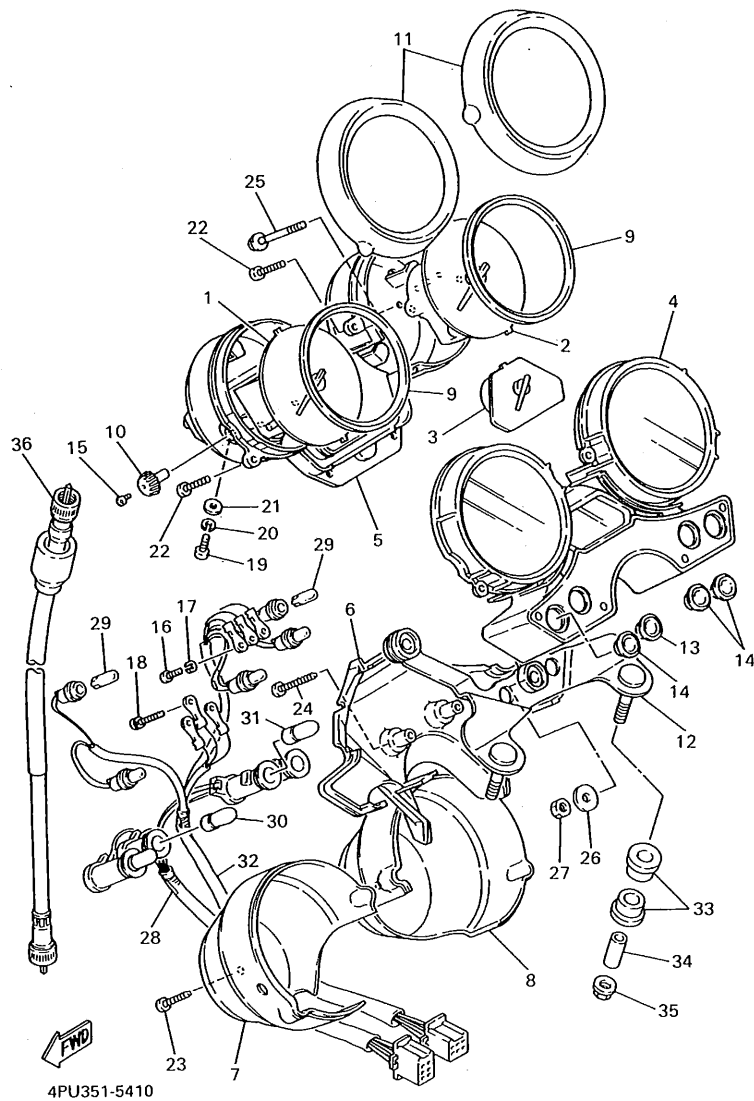
FIG. 41 METER



4PU351-5410

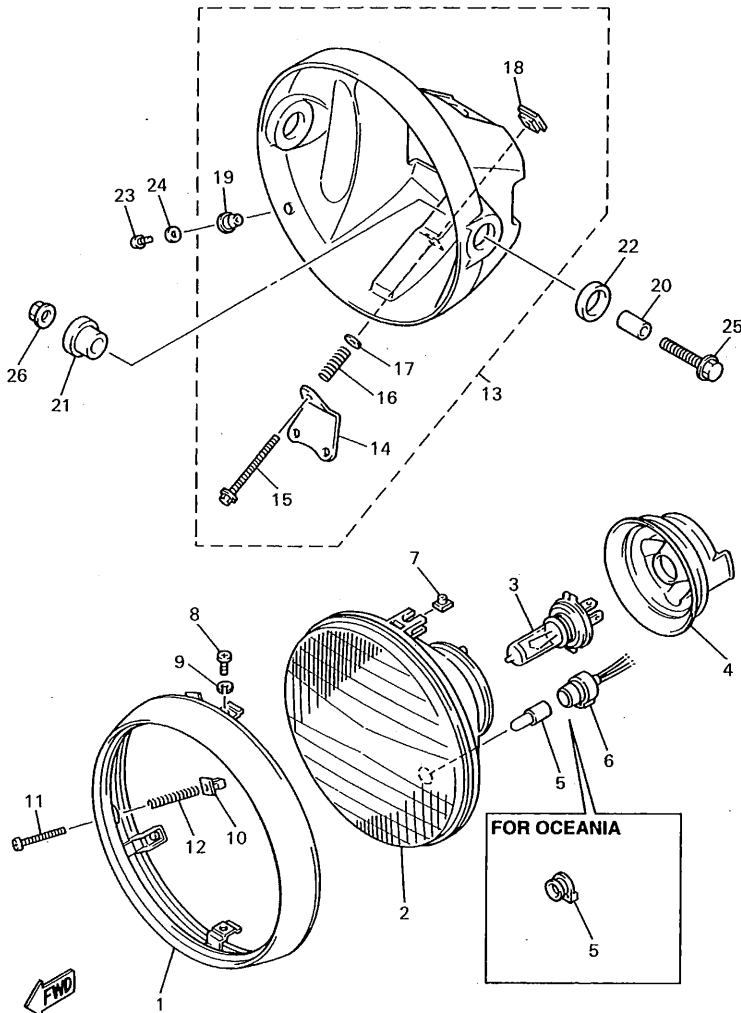
REF. NO.	PART NO.	DESCRIPTION	Q'TY	REMARKS
1	4PU-83570-00	SPEEDOMETER ASSY	1	UR
	4PU-83570-10	SPEEDOMETER ASSY	1	UR FOR ENGLAND
2	4KG-83540-00	TACHOMETER ASSY	1	
3	4HM-85750-00	FUEL METER ASSY	1	
4	4KG-8353E-00	CASE, METER UPPER	1	UR FOR OCEANIA
	4PU-8353E-20	CASE, METER UPPER	1	UR
5	4PU-8353F-00	CASE, METER LOWER	1	
6	4HM-83559-00	COVER, METER	1	
7	4HM-83507-00	COVER, SPEEDOMETER	1	
8	4HM-83508-00	COVER, TACHOMETER	1	
9	4HM-8353L-00	REFLECTOR	2	
10	1AE-83578-00	KNOB, TRIP METER	1	
11	4HM-83506-00	RING, METER COVER	2	
12	4KG-83519-00	BRACKET, METER	1	
13	4HM-83532-20	LENS, PILOT	1	
14	4HM-83532-30	LENS, PILOT	3	
15	90157-02031	SCREW, PAN HEAD	1	
16	98507-03010	SCREW, PAN HEAD	3	
17	92990-03100	WASHER, SPRING	3	
18	90159-03102	SCREW, WITH WASHER	3	
19	98507-04030	SCREW, PAN HEAD	2	
20	92907-04100	WASHER	2	
21	92907-04600	WASHER	2	
22	97707-40516	SCREW, TAPPING	4	
23	97707-40014	SCREW, TAPPING	2	
24	97707-40030	SCREW, TAPPING	2	
25	90167-04057	SCREW, TAPPING	2	
26	90201-052E2	WASHER, PLATE	3	

FIG. 41 METER



REF. NO.	PART NO.	DESCRIPTION	Q'TY	REMARKS
27	95307-05600	NUT	3	
28	4KG-83509-00	SOCKET CORD ASSY	1	
29	2GV-83517-00	BULB, (12V-1.7W, T6.5)	5	
30	4G1-84744-00	BULB (12V-3.4W)	1	
31	3GM-83517-00	BULB (12V-1.7W)	3	
32	4PU-83520-00	SOCKET CORD ASSY	1	
33	1JK-83541-00	DAMPER	4	
34	90387-06676	COLLAR	2	
35	95707-06500	NUT, FLANGE	2	
36	4KG-83550-01	SPEEDOMETER CABLE ASSY	1	

FIG. 42 HEADLIGHT



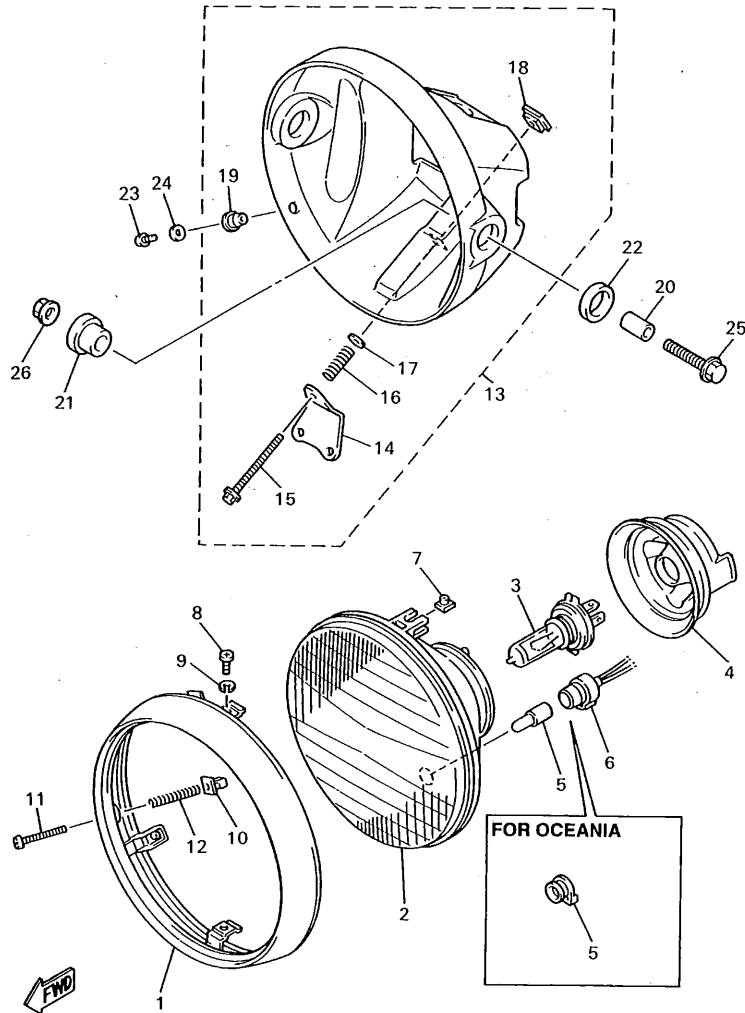
REF. NO.	PART NO.	DESCRIPTION	Q'TY	REMARKS
1	4KG-84315-00	RIM, HEADLIGHT	1	
2	4PU-84320-00	LENS ASSY	1	UR
	4PU-84320-10	LENS ASSY	1	UR FOR ENGLAND
	4KG-84320-00	LENS ASSY	1	UR FOR OCEANIA
3	2F9-84314-00	BULB (12V-60/55W)	1	(H4) HALOGEN
4	4KG-84397-00	COVER, SOCKET	1	
5	4E2-84347-00	BULB (12V-4W)	1	UR
	4KG-84154-00	GROMMET	1	UR FOR OCEANIA
6	4PU-84346-00	SOCKET, PILOT LIGHT	1	EXCEPT FOR OCEANIA
7	4KG-84334-00	NUT, ADJUSTING	2	
8	4KG-84365-00	SCREW	2	
9	92995-06100	WASHER, SPRING	2	
10	47J-84334-00	NUT, ADJUSTING	1	
11	4KG-84331-00	SCREW, RIM ADJUSTING	1	
12	4KG-84332-00	SPRING, SCREW	1	
13	4KG-84330-00	BODY ASSY	1	
14	4KG-84318-00	•STAY, HEADLIGHT 1	1	
15	4KG-8433E-00	•SCREW, ADJUSTING	1	
16	4KG-84335-00	•SPRING	1	
17	4KG-84344-00	•WASHER, PLAIN	1	
18	4KG-84326-00	•NUT	1	
19	5G2-84333-00	•SCREW	2	
20	90387-0804N	COLLAR	2	
21	4KG-84366-00	DAMPER, HEADLIGHT 1	2	
22	4KG-84367-00	DAMPER, HEADLIGHT 2	2	
23	98507-05016	SCREW, PAN HEAD	2	
24	92907-05600	WASHER	2	
25	95024-08040	BOLT, FLANGE	2	

4PU300-6420



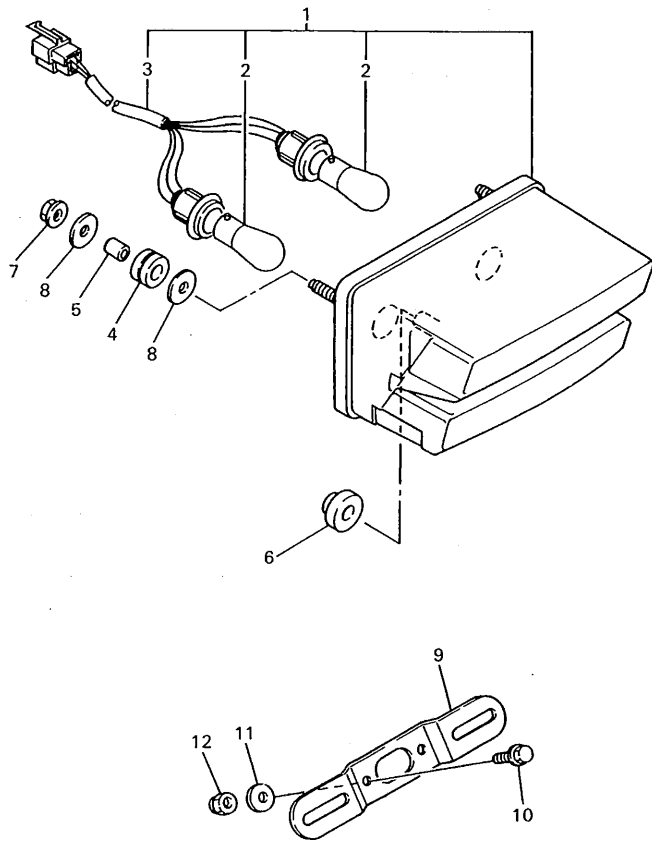
FIG. 42 HEADLIGHT

REF. NO.	PART NO.	DESCRIPTION	Q'TY	REMARKS
26	95707-08500	NUT, FLANGE	2	



4PU300-6420

FIG. 43 TAILLIGHT

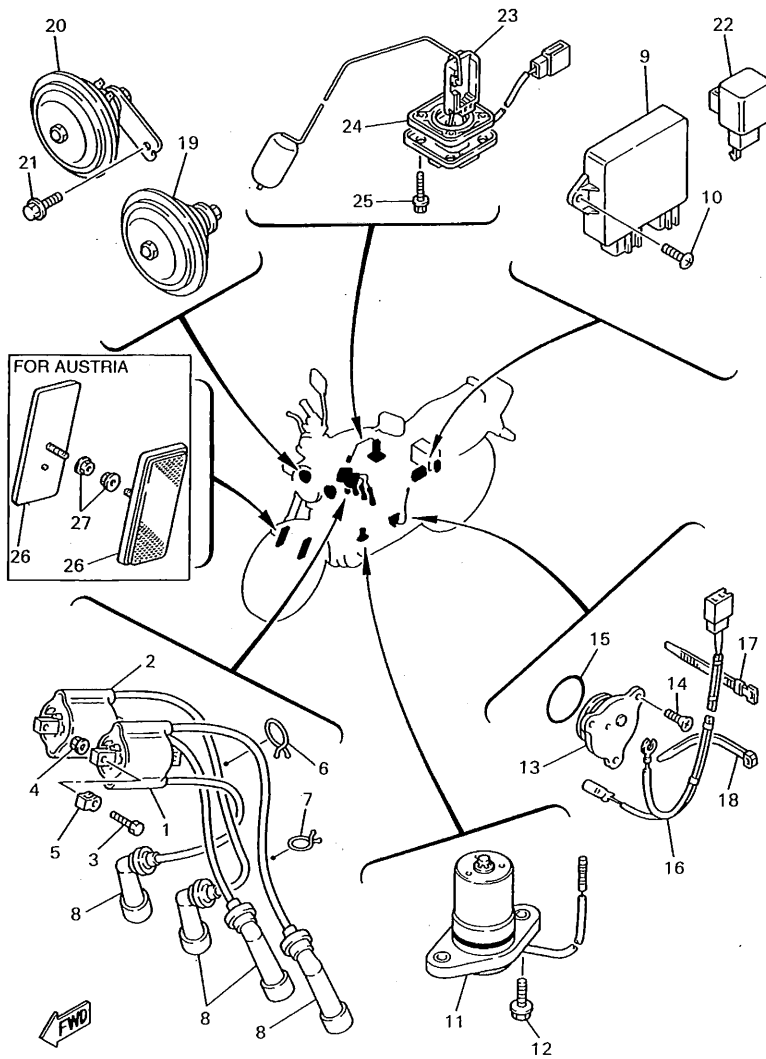


REF. NO.	PART NO.	DESCRIPTION	Q'TY	REMARKS
1	4PU-84710-00	TAILLIGHT UNIT ASSY	1	
2	31L-84714-00	BULB, TAILLIGHT (12V-21/5W)	2	
3	4HM-84735-00	CORD ASSY	1	
4	90480-18276	GROMMET	2	
5	90387-0600V	COLLAR	2	
6	90480-10509	GROMMET	1	
7	95707-06500	NUT, FLANGE	2	
8	90201-063J2	WASHER, PLATE	4	
9	3YF-84751-00	BRACKET, LICENSE	1	
10	95027-06016	BOLT, FLANGE	2	
11	90201-06059	WASHER, PLATE	2	
12	95617-06100	NUT, U	2	



4KG010-4430

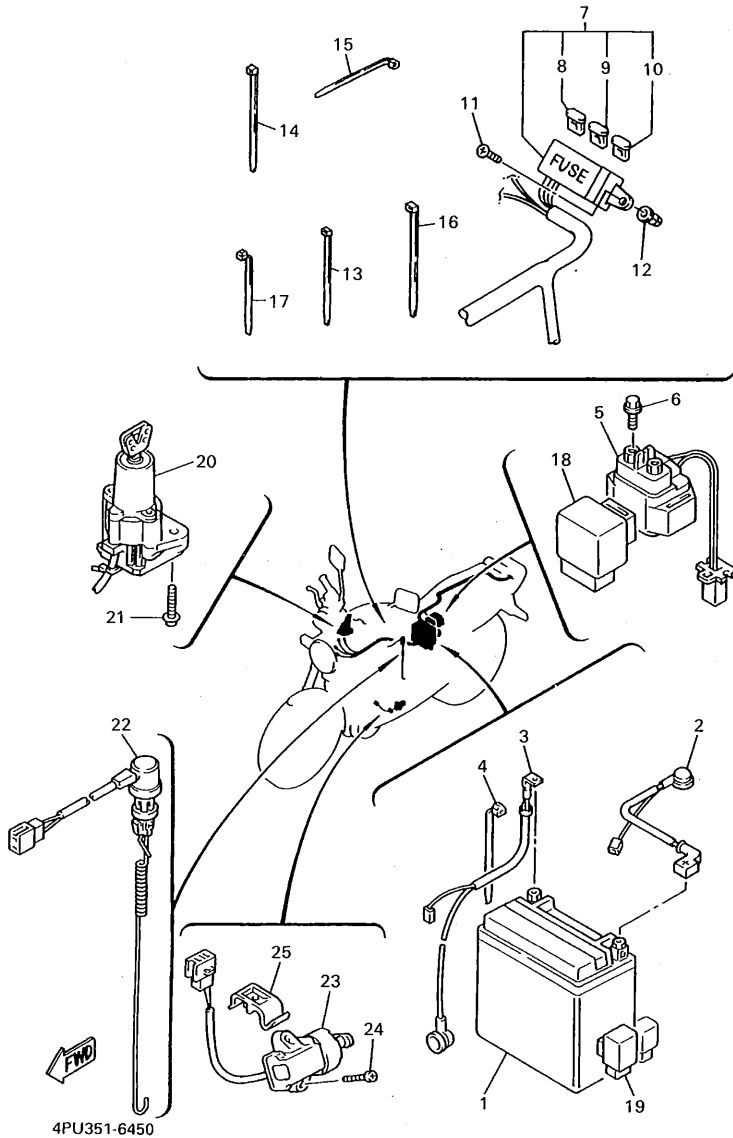
FIG. 44 ELECTRICAL 1



4PU300-5440

REF. NO.	PART NO.	DESCRIPTION	Q'TY	REMARKS
1	4KG-82310-00	IGNITION COIL ASSY	1	
2	4KG-82320-00	IGNITION COIL ASSY	1	
3	97080-06070	BOLT	2	
4	95707-06500	NUT, FLANGE	2	
5	4BR-82317-00	DAMPER, IGNITION COIL	4	
6	90464-30040	CLAMP	1	
7	90464-16039	CLAMP	1	
8	1UY-82370-20	PLUG CAP ASSY	4	
9	4PU-82305-00	IGNITOR UNIT ASSY	1	UR
	4RB-82305-00	IGNITOR UNIT ASSY	1	UR FOR CHE, AUT
10	98907-06016	SCREW, BIND	2	
11	5G2-85720-00	OIL LEVEL GAUGE ASSY	1	
12	95027-06016	BOLT, FLANGE	2	
13	1L9-82540-00	NEUTRAL SWITCH ASSY	1	
14	98707-05012	SCREW, FLAT HEAD	3	
15	93210-29196	O-RING	1	
16	4KG-82509-00	WIRE, SUB LEAD	1	
17	80L-26397-00	BAND	1	
18	90464-13073	CLAMP	1	
19	4KG-83371-01	HORN	1	
20	4KG-83371-11	HORN	1	
21	95817-06012	BOLT, FLANGE	2	
22	3GM-83350-01	FLASHER RELAY ASSY	1	
23	4KG-85752-00	SENDER UNIT ASSY, FUEL METER	1	
24	5G3-85753-00	GASKET, SENDER UNIT	1	
25	90119-05071	BOLT, WITH WASHER	4	
26	11H-85110-01	REFLECTOR ASSY	2	FOR AUSTRIA
27	95707-05500	NUT, FLANGE	2	FOR AUSTRIA

FIG. 45 ELECTRICAL 2



REF. NO.	PART NO.	DESCRIPTION	Q'TY	REMARKS
1	3XW-82100-00	BATTERY ASSY (YTX14-BS)	1	
2	4KG-82115-00	WIRE, PLUS LEAD	1	
3	4KG-82116-00	WIRE, MINUS LEAD	1	
4	90464-13073	CLAMP	1	
5	4KG-81940-00	STARTER RELAY ASSY	1	
6	95027-06008	BOLT, FLANGE	2	
7	4PU-82590-10	WIRE HARNESS ASSY	1	UR
	4UW-82590-00	WIRE HARNESS ASSY	1	UR FOR OCEANIA
8	1AE-82151-00	.FUSE (30A-BL)	2	
9	36Y-82151-00	.FUSE (15A-BL)	3	
10	2KW-82151-00	.FUSE (7.5A-BL)	2	
11	97707-60016	SCREW, TAPPING	2	
12	90338-08226	PLUG	2	
13	12R-82591-00	BAND	2	
14	90464-13080	CLAMP	6	
15	90464-13073	CLAMP	1	
16	90464-13080	CLAMP	1	
17	90464-13073	CLAMP	1	
18	4EP-81950-00	RELAY ASSY	1	
19	4BH-8195A-00	RELAY ASSY	1	
20	4PU-82501-00	MAIN SWITCH STEERING LOCK	1	UR
	4KG-82501-01	MAIN SWITCH STEERING LOCK	1	UR FOR OCEANIA
21	90109-080G5	BOLT	2	
22	3YF-82530-01	STOP SWITCH ASSY	1	
23	3LD-82566-90	SWITCH, SIDE STAND	1	
24	90157-05079	SCREW, PAN HEAD	2	
25	90464-05187	CLAMP	1	

# INDEX

NUMERICAL INDEX

PART NO.	GRID NO.	PART NO.	GRID NO.
4KO-W0041-50	E - 3	4PU-11631-00-A0	B - 4
3TU-W0042-51	E - 7	30X-11633-03	B - 4
4KG-W0045-00	D -12	4PU-11636-00	B - 4
1FK-W0046-02	D -15	36Y-11650-01	B - 4
1NL-W0047-00	D -12	36Y-11654-00	B - 4
31A-W0047-00	D -15	36Y-11656-00	B - 4
1J3-W0048-00	D -12	36Y-11656-10	B - 4
	D -15	36Y-11656-20	B - 4
	C - 7	36Y-11656-30	B - 4
36Y-W0048-00	D -12	36Y-12111-00	B - 5
1NL-W0057-00	D -15	36Y-12113-00	B - 5
31A-W0057-00	C - 7	36Y-12114-00	B - 5
26H-W0098-00	E - 4	26H-12116-00	B - 5
3GM-W0099-00	C - 3	30X-12117-00	B - 5
3XW-W1543-00	C - 8	30X-12118-00	B - 5
4KG-W1741-00	E - 3	51Y-12119-00	B - 5
4HM-W2585-00	E - 4	36Y-12121-00	B - 5
	E - 3	26H-12153-00-J0	B - 6
4KG-W2587-00	E - 4	26H-12153-00-Y0	B - 6
4KG-W2645-00	D - 2	26H-12168-A0	B - 5
4KG-Y2171-10-0X	D - 2	26H-12168-F0	B - 5
4KG-Y2171-10-1X	D - 2	26H-12168-H0	B - 5
4KG-Y2172-10-0X	D - 2	26H-12168-K0	B - 5
4KG-Y2172-10-1X	B - 2	26H-12168-M0	B - 5
4KG-11101-00	B - 2	26H-12168-R0	B - 5
4KG-1111G-00	B -15	26H-12168-U0	B - 5
3XW-1111J-00	B -15	26H-12168-W0	B - 5
3XW-1112J-00	B - 2	26H-12168-Y0	B - 5
36Y-11133-10	B - 2	26H-12168-00	B - 5
434-11161-00	C - 2	26H-12168-20	B - 5
4KG-11166-00	B - 2	26H-12168-40	B - 5
1TX-11181-00	B - 2	26H-12168-60	B - 5
4KG-11191-01	B - 2	26H-12168-80	B - 5
36Y-11193-00	B -10	26H-12169-E0	B - 6
214-11198-01	B - 3	26H-12169-G0	B - 6
1TX-11310-01	B - 3	26H-12169-J0	B - 6
4CR-11351-00	B - 3	26H-12169-L0	B - 6
3XW-11363-01	B -15	26H-12169-N0	B - 6
3XW-11364-01	B - 4	26H-12169-T0	B - 5
36Y-11411-01	B - 4	26H-12169-30	B - 5
2H7-11416-01	B - 4	26H-12169-50	B - 5
2H7-11416-11	B - 4	26H-12169-70	B - 5
2H7-11416-21	B - 4	26H-12169-90	B - 5
2H7-11416-31	B - 4	47M-12171-00	B - 7
4FM-11456-00	C - 5	36Y-12171-00	B - 7
36Y-11474-00	C - 5	36Y-12178-10	B - 2
4PU-11603-00	B - 4	47M-12181-00	B - 7
4PU-11605-00	B - 4		

NUMERICAL INDEX

PART NO.	GRID NO.	PART NO.	GRID NO.
4GB-14940-00	B -12	341-16321-13	C - 6
3XW-14984-00	B -12	2H7-16325-00	C - 6
3H5-14985-00	B -12	36Y-16331-00	C - 6
50H-14987-00	B -13	36Y-16334-00	C - 6
36Y-14988-00	B -13	36Y-16335-00	C - 6
22F-14991-00	B -13	36Y-16351-00	C - 6
4KG-14995-00	B -13	1TX-16352-00	C - 6
3XW-15100-02	B -15	4KG-16356-00	C - 6
36Y-15163-00	C - 5	4KG-16357-00	C - 6
4H7-15167-10	B -15	36Y-16371-00	C - 6
36Y-15189-00	B -10	36Y-16381-11	C - 7
4KO-15189-00	C - 2	36Y-16383-00	C - 6
36Y-15317-00	C - 2	36Y-16384-00	C - 6
1TX-15333-00	C - 3	2H7-16385-00	C - 6
36Y-15336-00	C - 2	3CV-17121-00	C - 8
1TX-15346-00	C - 3	1TX-17131-00	C - 8
2H7-15361-00	C - 4	4CC-17141-00	C - 8
3F9-15362-00	C - 3	1TX-17151-00	C - 8
1TX-15365-00	C - 2	1TX-17211-00	C - 8
1TX-15367-00	C - 3	3CV-17221-00	C - 8
4CR-15374-00	C - 3	1TX-17231-00	C - 8
36Y-15383-01	C - 2	4CC-17241-00	C - 8
36Y-15389-09	B - 4	1TX-17251-00	C - 8
4KG-15411-00	C - 3	4KG-17421-00	C - 8
36Y-15412-00	C - 2	4KG-17460-00	C - 8
36Y-15416-00	C - 3	4KG-18101-01	C -11
36Y-15417-01	C - 3	4KG-18111-00	C -11
36Y-15426-00	C - 3	2GH-18112-01	C -11
36Y-15449-00	C - 3	132-18113-01	C -11
4KG-15449-00	C - 3	2GV-18115-00	C -11
4CR-15451-00	C - 3	4GO-18127-00	C -11
4CR-15461-00	C - 3	36Y-18140-00	C -10
4CR-15467-00	C - 3	2H9-18154-00	C -11
4KG-15481-01	C - 3	3XW-18511-00	C -10
4H7-15486-00	C - 3	4KG-18512-00	C -10
36Y-15512-01	C - 5	3XW-18513-00	C -10
36Y-15517-01	C - 5	4BR-18531-00	C -10
36Y-15519-00	C - 5	3XW-18540-00	C -10
36Y-15521-01	C - 5	278-18542-00	C -10
3CV-15522-00	C - 5	36Y-18562-00	C -10
12R-15524-00	C - 5	278-18566-00	C -10
2H7-15531-00	C - 5	4PU-21110-00-33	C -12
36Y-15580-02	B -12	4KG-21150-00-33	C -12
1J7-15583-01	C - 5	4PU-2117E-00	C -13
1TX-16150-01	C - 6	3YX-21308-00	D -10
36Y-16154-00	C - 6	4KG-21315-01	C -12
4H7-16155-01	C - 5	4KG-21331-00	C -14
36Y-16181-00	C - 6	4KG-21332-00	C -14
4GO-14197-00	B -13		
4HM-14216-00	B -13		
3G2-14231-26-A0	B -13		
3G2-14231-27	B -13		
620-14231-19	B -12		
17A-14251-00	B -13		
4KG-14285-00	B -13		
4KG-14401-00	B -11		
4KG-14412-00	B -11		
31A-14419-00	B -11		
1HX-1443E-00	B -11		
31A-14435-00	B -11		
4KG-14437-00	B -11		
4KG-14451-00	B -11		
31A-14453-00	B -11		
34X-14457-00	B -11		
36Y-14463-00	B -11		
4KG-14461-00	B -10		
4KG-14612-00	B -10		
4BE-14613-00	B -10		
4PU-14615-00	B -14		
4KG-14621-00	C - 5		
4KG-14631-00	B -10		
4GO-14638-00	B - 9		
4KG-14644-00	B - 9		
4PU-14711-01	B -14		
3XW-14714-00	B -14		
4PU-14721-01	B -14		
36Y-14747-00	B -14		
3XW-14755-00	B -14		
4KG-14791-00	B -14		
4KG-1490J-01	B -12		
4RB-1490J-01	B -12		
3KW-1490K-00	B -13		
4KG-1490L-10	B -13		
4KG-14900-30	B -12		
4RB-14900-10	B -12		
4KG-14901-30	B -12		
4RB-14901-10	B -12		
4KG-14902-30	B -12		
4RB-14902-10	B -12		
4KG-14903-30	B -12		
4RB-14903-10	B -13		
4KG-14904-30	B -12		
4RB-14904-10	B -12		
4HM-14919-10	B -13		
3Y6-14933-00	B -12		
4KG-14940-00	B -12		



NUMERICAL INDEX

PART NO.	GRID NO.	PART NO.	GRID NO.	PART NO.	GRID NO.
4HM-83508-00	E -13	4KG-84367-00	E -15	90109-080G5	F - 5
4KG-83509-00	E -14	4KG-84397-00	E -15	90109-081G0	E - 6
2GV-83517-00	E -14	4PU-84710-00	F - 3	90109-08718	D -12
3GM-83517-00	E -14	31L-84714-00	F - 3		D -15
4KG-83519-00	E -13	4HM-84735-00	F - 3	90109-100G0	E - 6
4PU-83520-00	E -14	4G1-84744-00	E -14	90109-101E6	E - 5
4KG-8353E-00	E -13	3YF-84751-00	F - 3	90109-103A9	E - 6
4PU-8353E-20	E -13	11H-85110-01	F - 4	90109-104E6	E - 5
4PU-8353F-00	E -13	23V-85110-00	C -15	90110-05112	D - 8
4HM-8353L-00	E -13	3G1-85130-01	C -14	90110-06237	B -10
4HM-83532-20	E -13	4CF-85130-00	C -14	90110-08199	C -12
4HM-83532-30	E -13	4KG-85132-00	C -14	90110-08231	C -12
4KG-83540-00	E -13	5G2-85720-00	F - 4	90110-08232	C -12
1JK-83541-00	E -14	4HM-85750-00	E -13	90116-10485	D -13
4KG-83550-01	E -14	4KG-85752-00	F - 4	90116-10561	B -15
4HM-83559-00	E -13	5G3-85753-00	F - 4	90116-10562	B -15
4PU-83570-00	E -13	4KG-85885-00	B -13	90116-10563	B -15
4PU-83570-10	E -13	90101-06576	B -14	90119-05071	F - 4
1AE-83578-00	E -13	90101-08766	D -13	90149-04278	C -13
4PU-83912-00	E - 4	90105-060A0	C - 4	90149-05110	B -10
4PU-83922-00	E - 3		E -11	90149-06008	D - 8
437-83936-01	E - 4	90105-060A1	B -15	90149-06228	C - 5
4PU-83963-00	E - 2	90105-060A2	B -15	90149-06298	D - 2
4UW-83972-00	E - 2	90105-06305	B - 2	90149-06308	D -10
4HM-83975-11	E - 2	90105-06424	B - 7	90150-06036	C -13
3FV-83980-00	E - 3	90105-06790	C - 4	90151-06025	C - 2
3GM-83980-00	E - 4	90105-06792	C - 3	90153-06029	B - 2
4KG-84154-00	E -15		C - 7	90154-05059	C -14
2F9-84314-00	E -15	90105-06798	C - 3	90154-05073	C - 3
4KG-84315-00	E -15	90105-06799	C - 4	90157-02031	E -13
4KG-84318-00	E -15	90105-07342	B - 7	90157-05027	E - 2
4KG-84320-00	E -15	90105-080A3	B -15	90157-05079	E - 5
4PU-84320-00	E -15	90105-080A5	E - 9		E - 6
4PU-84320-10	E -15	90105-08321	D -13		F - 5
4KG-84326-00	E -15	90105-100A4	B -15	90157-05095	C - 3
4KG-8433E-00	E -15	90105-10300	C -12	90159-03102	E -13
4KG-84330-00	E -15	90105-10313	C -12	90159-06056	E - 7
4KG-84331-00	E -15	90105-10323	C -12	90159-06058	C -12
4KG-84332-00	E -15	90105-10402	C -12	90159-06059	D - 2
5G2-84333-00	E -15	90105-10445	E -10	90159-06107	E -10
4KG-84334-00	E -15	90105-10609	C -12	90167-04057	E -13
47J-84334-00	E -15	90105-10638	D -12	90170-06228	C -11
4KG-84335-00	E -15		D -15	90170-20323	C - 6
4KG-84344-00	E -15	90105-12425	C -12	90176-06055	D - 5
4PU-84346-00	E -15	90109-063F1	C -13	90176-10078	B - 2
4E2-84347-00	E -15	90109-063F7	C -10	90176-22050	D - 5
4KG-84365-00	E -15	90109-063G3	C - 7	90179-08327	B - 4
4KG-84366-00	E -15	90109-066F0	B - 2	90179-10658	C -12

NUMERICAL INDEX

PART NO.	GRID NO.	PART NO.	GRID NO.	PART NO.	GRID NO.
90267-40076	C -15	90464-12036	C -14	90179-22063	C - 9
90267-40090	D - 3	90464-13073	D - 9	90179-25033	D - 5
90331-15039	C - 5		F - 4	90183-05061	C -14
90338-06233	D - 2		F - 5	90183-06053	C -13
90338-08163	D - 5	90464-13080	D - 2	90185-10037	E - 5
	D -10		F - 5	90185-10091	E - 5
	E - 7	90464-13194	E - 3	90201-04018	C -13
	F - 5	90464-14117	D - 8		C -15
90338-08226	B - 7	90464-15157	C -14	90201-052E2	E -13
90340-10108	B - 9	90464-15192	E - 4	90201-060A3	D - 3
90387-060A7	F - 3	90464-16039	F - 4	90201-06059	F - 3
90387-0600V	D - 3	90464-30040	D - 9	90201-063J2	F - 3
90387-064H8	E - 5		F - 4	90201-08083	E - 7
	E - 6	90465-08252	C - 2	90201-084G3	B - 3
	E -14	90465-08253	C - 2	90201-094G1	B -15
	E -15	90465-10251	C - 2	90201-10118	B - 7
90387-06676	C -12	90467-08021	D - 8		E - 3
90387-0804N	C -12	90467-09006	D - 8	90201-10128	E - 4
90387-1003V	E - 4	90467-10039	B -11	90201-102G9	E - 8
90387-1003W	E - 6	90467-11106	B -11	90201-106H7	B - 2
90387-1005B	C -11	90467-12052	D - 8	90201-106G7	B - 2
90387-114K8	D -11	90467-13064	D - 9	90201-10669	B - 8
90387-17530	C - 5	90467-14015	C - 2	90201-12575	E - 6
90387-201L2	D -14	90467-14057	D - 8	90201-12588	C -11
90387-202X9	D -14		E - 7	90201-18264	D -14
90387-203X0	C - 8	90480-01558	D - 2	90201-18264	D -14
90387-220R2	E - 4	90480-10509	F - 3	90201-203F0	D - 3
90387-22660	C - 9	90480-12475	B - 9	90201-21608	B -10
90387-250R3	C - 6	90480-13398	C -13	90201-226H9	C - 8
90387-284K1	C - 9	90480-13567	C -12	90201-226H9	C - 8
90387-300R4	C - 8	90480-16284	B - 9	90201-257H0	C - 8
90387-3003P	C - 8	90480-18284	F - 3	90201-286H8	C - 6
90387-350R5	E - 3	90501-05764	C - 5	90201-307H1	C - 8
90401-10159	E - 4	90501-06022	C -10	90202-05187	D - 8
	E - 7	90501-12743	E - 5	90202-06113	C -14
	E - 3		E - 6		D - 2
90401-10160	E - 4	90501-153A2	B - 7	90202-24190	D - 5
	D - 8	90501-20422	B -10	90202-26142	D - 5
90413-11025	B -10	90506-26467	E - 5	90206-17084	E - 6
90430-05126	B - 2	90506-45278	E - 5	90209-06096	C - 3
90430-06014	B -10	90508-20737	E - 7	90209-06174	B - 9
	B - 3	90508-23707	C -10	90209-25196	C - 8
90430-14131	D - 8	90508-32682	C -11	90209-27192	C - 8
90445-104H3	B -11	90560-17356	D -11	90209-32231	C - 8
90445-11153	B -11	90560-20357	D -13	90215-25218	C - 6
90460-58015	C - 2	91314-08020	E - 7	90215-26241	C - 9
90462-10145	F - 5	91314-08030	D - 5	90240-08124	E - 7
90464-05187	E - 4	91314-08045	D - 7	90249-04184	B - 7
90464-10190				90267-40076	C -14



NUMERICAL INDEX

PART NO.	GRID NO.	PART NO.	GRID NO.
91317-05010	D - 8	93210-13657	B - 8
91317-05035	E - 2		B - 9
91317-06010	C - 2	93210-15566	B - 8
91317-06020	B - 9	93210-16629	B - 9
	B - 10		B - 10
	B - 11	93210-20573	C - 2
	E - 3	93210-26658	B - 8
	E - 4	93210-27778	C - 3
91317-06025	B - 7	93210-29196	F - 4
	B - 10	93210-30660	C - 8
91317-06040	B - 9	93210-40659	B - 11
91317-06045	E - 5	93210-47440	C - 5
	E - 6	93210-81731	B - 3
91317-08016	C - 5	93210-87723	B - 10
91317-08025	D - 7	93305-20605	C - 8
	D - 10	93306-00315	C - 6
91490-20025	D - 13	93306-00426	C - 5
	E - 7	93306-20314	D - 11
92014-06012	B - 9	93306-20545	C - 5
92901-04600	E - 3	93306-20561	C - 9
92901-05100	B - 13	93306-30416	D - 13
	E - 9	93306-30434	C - 8
92907-04100	E - 13	93306-30437	D - 13
92907-04600	E - 13	93306-30562	D - 13
92907-05600	C - 2	93306-36401	C - 8
	E - 15	93310-350M3	C - 6
92907-06200	B - 9	93315-23607	B - 8
92907-06600	B - 3	93315-42523	D - 3
	C - 2	93317-21236	C - 3
92907-08600	B - 14	93317-42060	C - 2
92907-10200	C - 12	93399-99931	D - 5
92990-03100	E - 13	93399-99932	D - 5
92990-04100	E - 3	93440-09139	B - 8
92990-05600	E - 9	93440-28062	C - 8
92990-08600	B - 14	93440-30077	C - 8
92995-06100	E - 15	93440-34025	C - 8
93102-12106	C - 11	93440-52118	C - 9
93102-25017	D - 11	93440-62032	C - 9
93102-25253	C - 5	93450-19052	B - 4
93102-40330	C - 8	93501-04011	E - 5
93105-45017	D - 11		E - 6
93106-30029	D - 13	93511-32027	C - 6
93106-35030	D - 13	93604-08071	E - 10
93109-08061	C - 6	93615-17125	C - 5
93109-12053	C - 11	93626-08210	B - 8
93210-06632	C - 6	93900-00030	D - 11
93210-07438	B - 15		D - 13
93210-10096	B - 10	94113-1704W	D - 11

NUMERICAL INDEX

PART NO.	GRID NO.	PART NO.	GRID NO.
95707-05500	F - 4	98507-04030	E - 13
95707-06500	D - 10	98507-05010	B - 12
	E - 14		B - 13
	F - 3	98507-05016	B - 13
	F - 4		E - 15
95707-08500	D - 13	98507-05018	E - 9
	F - 2	98507-05025	E - 2
95707-12500	E - 12	98507-05045	E - 2
95807-06016	B - 11	98517-04012	E - 3
	C - 13	98706-04016	E - 4
	C - 14	98707-04008	B - 13
	B - 14	98707-04012	E - 3
	B - 14		E - 4
95807-10040	F - 4	98707-05012	C - 10
95814-08025	B - 9		F - 4
95817-06012	B - 15	98707-06016	C - 10
95817-06020	B - 15	98907-06008	B - 10
95817-06030	B - 15	98907-06016	F - 4
95817-06040	B - 15	99006-10600	C - 11
95817-06055	B - 8	99237-00100	C - 14
95817-06070	B - 15	99510-08016	B - 2
95817-06095	B - 15		B - 10
95817-06110	B - 15		C - 3
95817-06125	C - 13	99510-12016	B - 15
95817-08012	B - 15	99530-10014	C - 3
95817-08045	B - 15	99530-14016	B - 3
95817-08055	B - 15		B - 15
95817-10060	B - 15		
95824-06020	C - 11		
97007-05010	C - 2		
97007-06012	E - 7		
97007-08030	D - 8		
97017-06016	C - 5		
	C - 6		
97017-08025	B - 14		
97024-08025	B - 14		
97027-06012	C - 3		
	C - 5		
97080-06070	F - 4		
97707-40014	E - 13		
97707-40030	E - 13		
97707-40516	E - 13		
97707-50510	D - 2		
97707-50525	B - 11		
97707-60016	F - 5		
97780-40120	E - 12		
98501-04006	B - 12		
98503-06014	B - 13		
98507-03010	E - 13		





*COPYRIGHT: All rights reserved. No part of this publication  
may be reproduced without permission.*

**YAMAHA**

YAMAHA MOTOR CO., LTD.

2500 SHINGAI IWATA SHIZUOKA JAPAN  
SERVICE INFORMATION DIV.

---

Printed in Japan  
First edition NOV., 1995